

Go to VARIAC.com
 to purchase and for
 technical support.
 Made in the USA

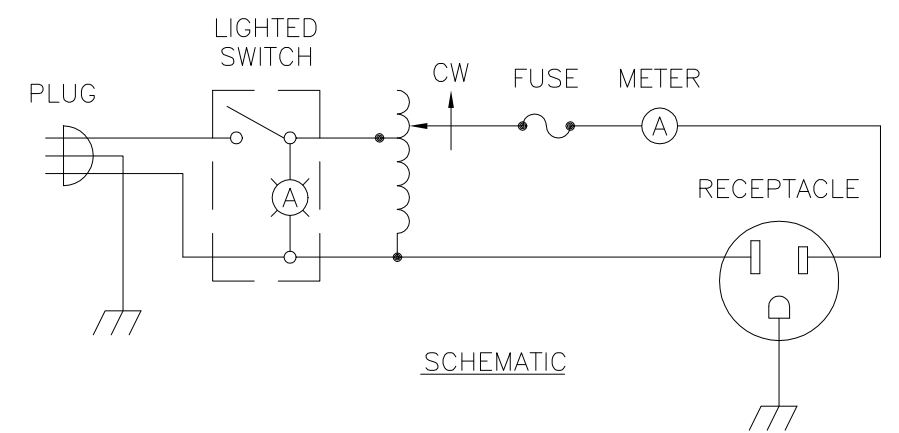
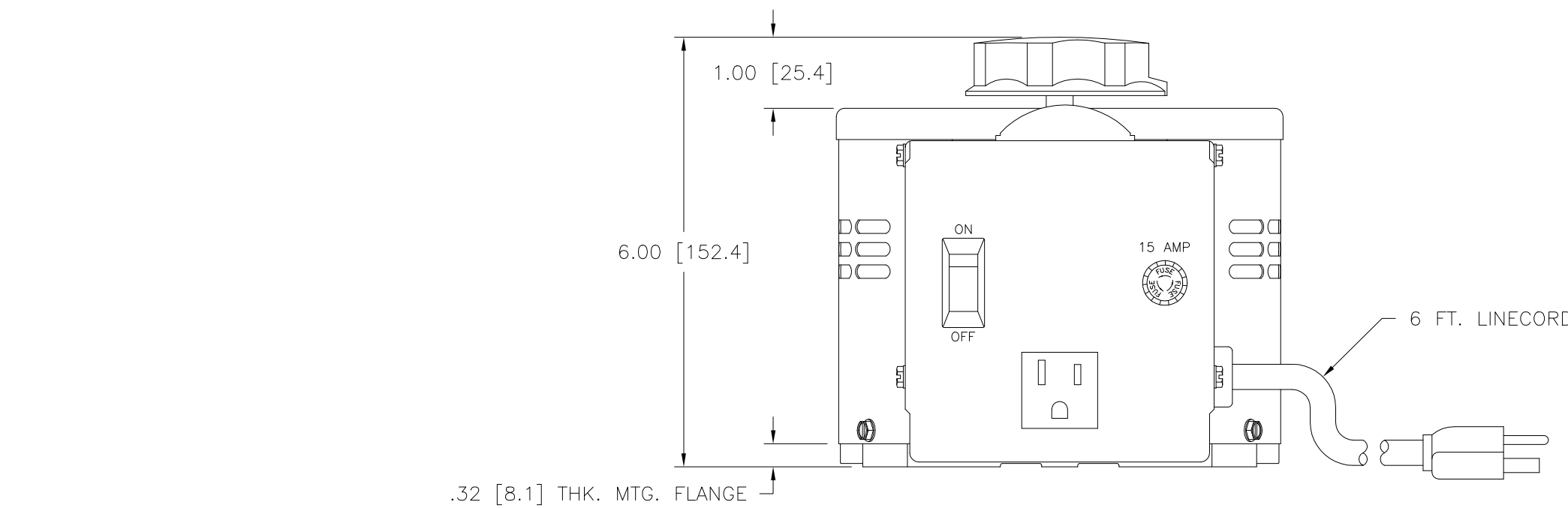
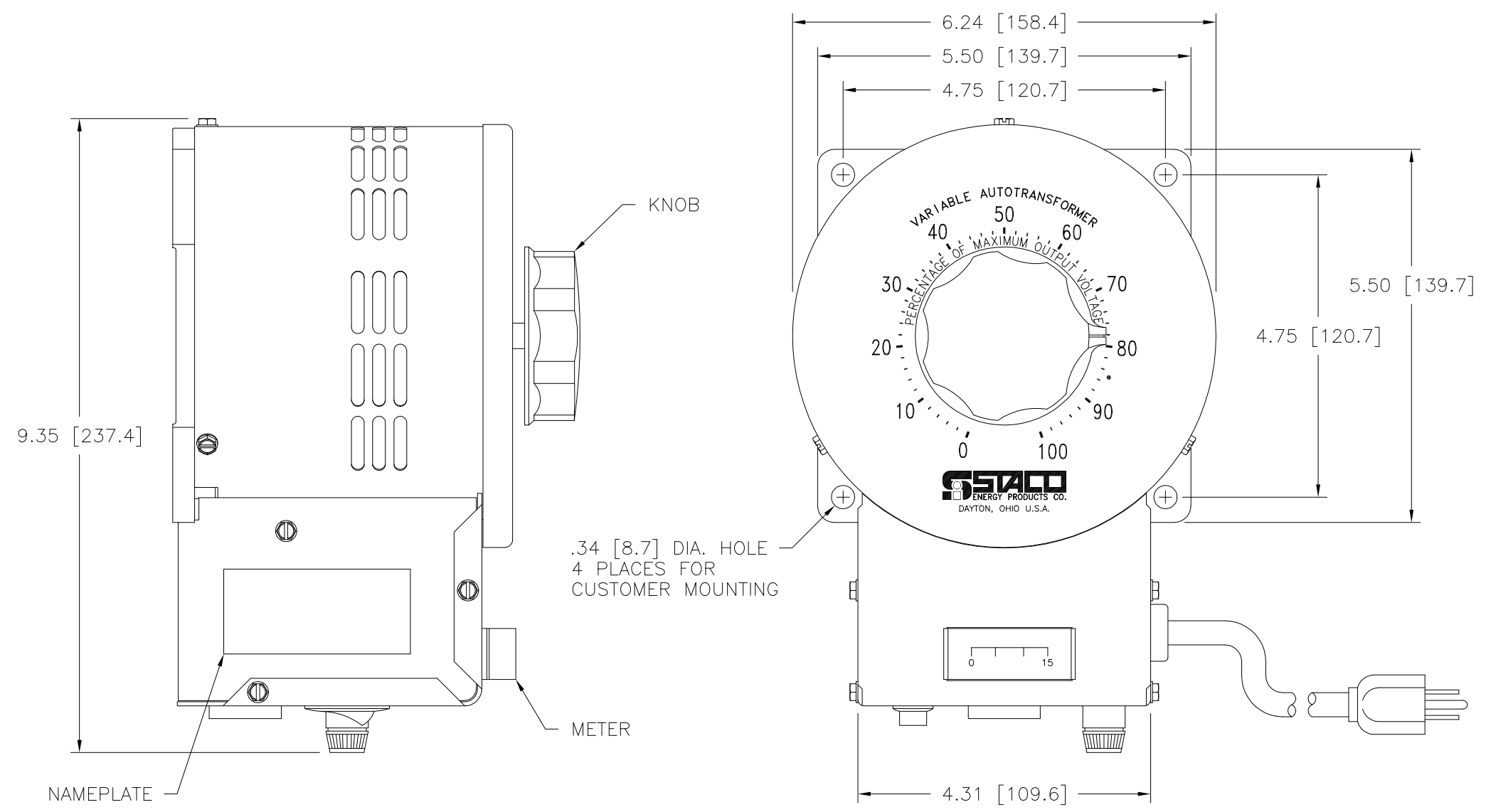

SPECIFICATIONS					
WIRING	INPUT		OUTPUT		
	VOLTS	HERTZ	VOLTS	CONSTANT CURRENT LOAD	
SINGLE PHASE	120	50/60	0-140	MAX. AMPS	MAX. KVA
				15	2.10

UNLESS OTHERWISE SPECIFIED, TOLERANCE IS # DECIMALS .XX .XXX .005 HOLES .01 ANGLES 1° DRAFT 1-1/2° UNITS IN [mm] MATERIAL: ALL DIMENSIONS APPLY AFTER PLATING

THE INFORMATION AND DESIGN DISCLOSED HEREIN WAS ORIGINATED BY AND IS THE PROPERTY OF STACO ENERGY PRODUCTS CO., WHICH RESERVES ALL PATENT, PROPRIETARY, DESIGN, MANUFACTURING, REPRODUCTION, USE AND SALE RIGHTS THEREIN, AND TO ANY ARTICLE DISCLOSED THEREIN EXCEPT TO THE EXTENT RIGHTS ARE EXPRESSLY GRANTED TO OTHERS. THE FOREGOING DOES NOT APPLY TO VENDOR PROPRIETARY PARTS.

TITLE: SPEC. CONTROL DRAWING VARIABLE TRANSFORMER MODEL: 3PN1510BA

DRAWN BY: S.A. SMITH	DATE: 5/16/96	FIRST USED ON: 3PN1510BA	DO NOT SCALE DWG.	CUSTOMER APPROVAL:	DATE:
CHECKER:	DATE:	WEIGHT APPROX. 18 LBS	CODE IDENT. NO. 83008	DWG. NO. 031-3647	
ENGINEER:	DATE:	SCALE 1=1	SHEET 1 OF 1		

STACO
 ENERGY PRODUCTS CO.
 A COMPONENTS CORPORATION OF AMERICA COMPANY
 DAYTON, OHIO U.S.A.