

Go to [VARIAC.com](http://VARIAC.com)  
 to purchase and for  
 technical support.  
 Made in the USA

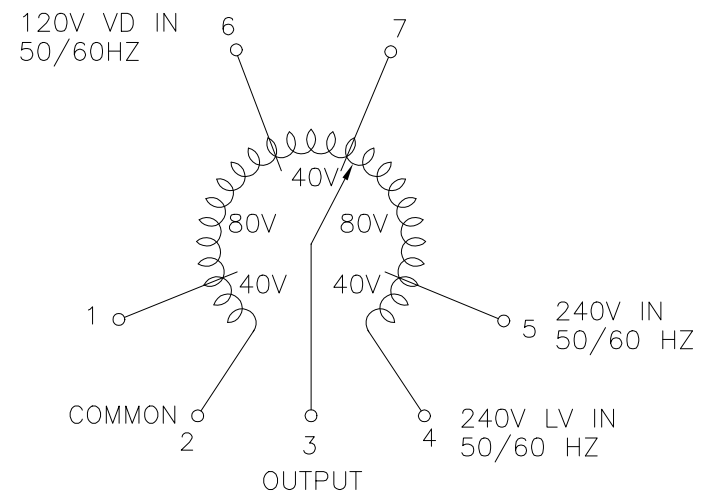

SCHEMATIC  
 VIEW FROM BASE END

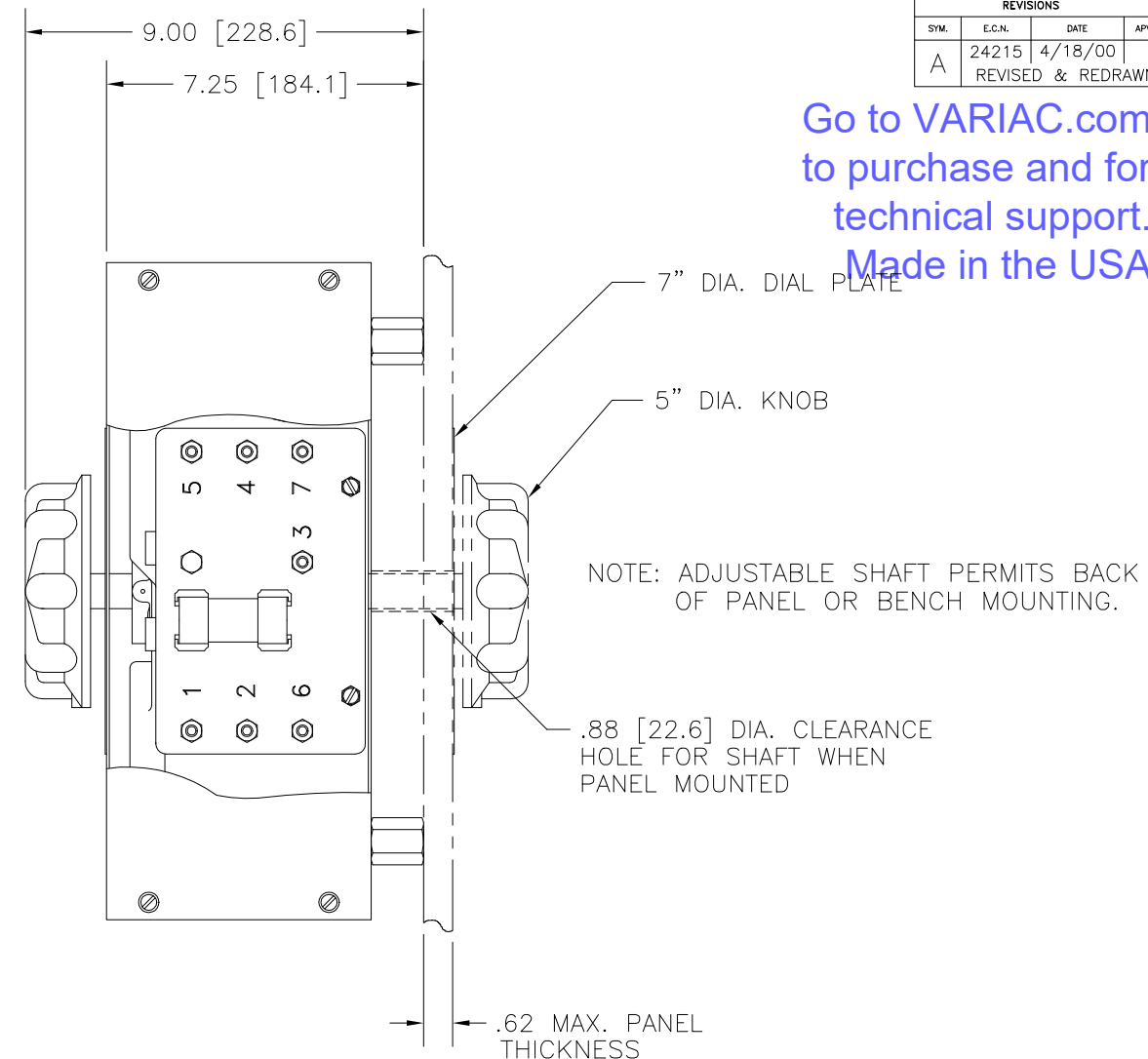
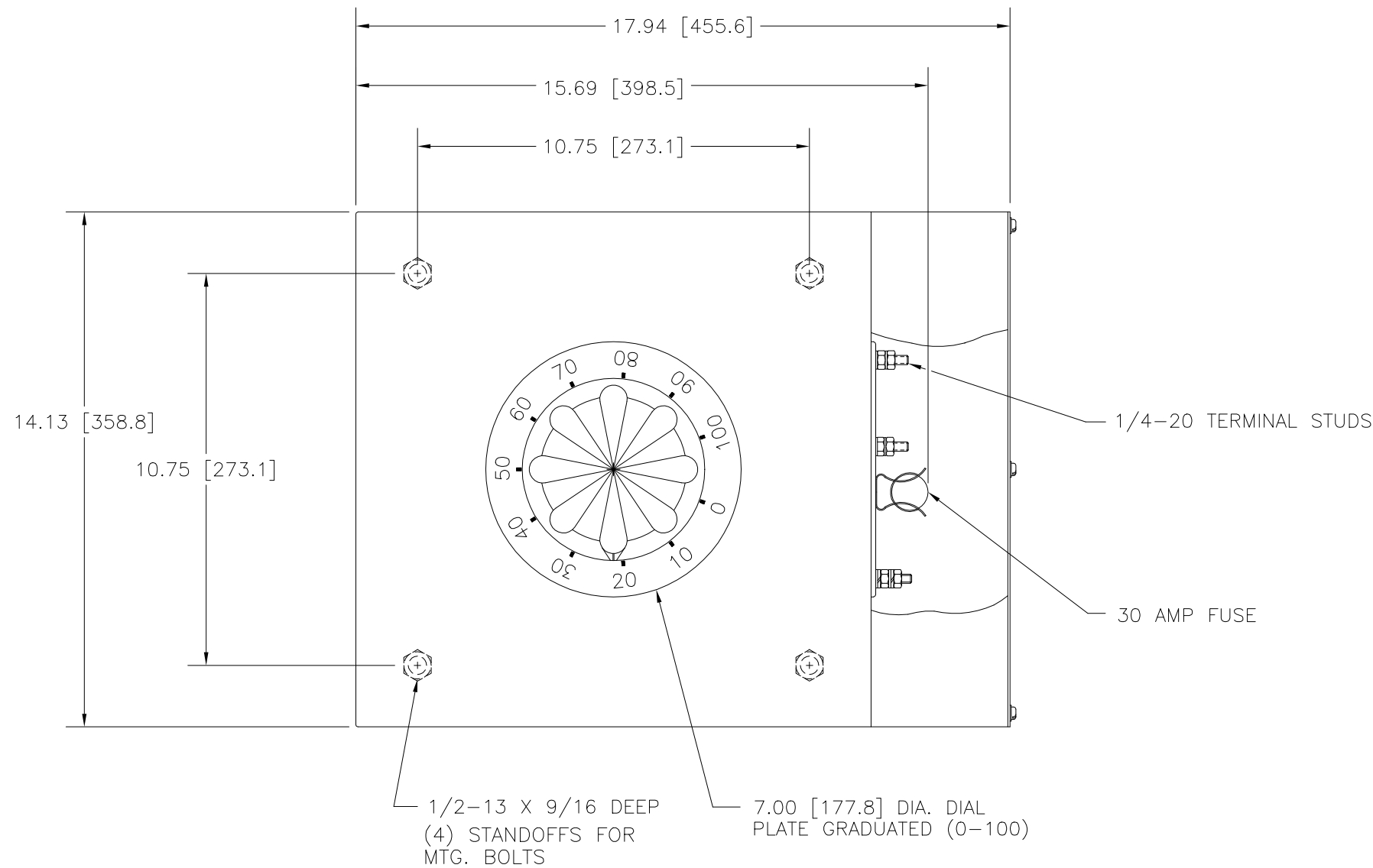
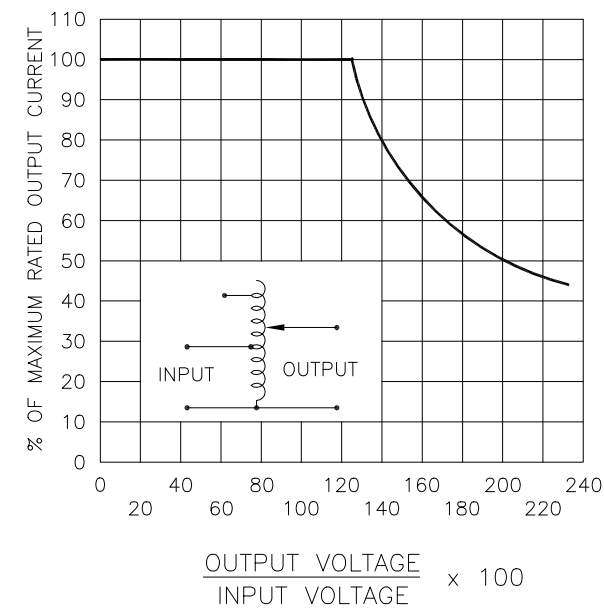

FIGURE A  
 MAXIMUM OUTPUT CURRENT OF ANY DUAL INPUT VOLTAGE OR VOLTAGE DOUBLER UNIT OPERATED AT LOWER INPUT VOLTAGE.

# MAXIMUM OUTPUT CURRENT IN OUTPUT VOLTAGE RANGE FROM 0 TO 25% ABOVE LINE VOLTAGE. AT HIGHER OUTPUT VOLTAGES, OUTPUT CURRENT MUST BE REDUCED ACCORDING TO RATING CURVE FIGURE A.

‡ MAXIMUM KVA AT MAXIMUM OUTPUT AND CORRESPONDING DE-RATED CURRENT. MAXIMUM KVA AT LOWER OUTPUT VOLTAGES MAY BE CALCULATED FROM RATING CURVE, FIGURE A.

SPECIFICATIONS								
WIRING	INPUT		OUTPUT			SHAFT ROTATION FOR INCREASE VOLTAGE	TERMINAL CONNECTIONS	
	VOLTS	HERTZ	VOLTS	MAX. AMPS	MAX. KVA		FOR INCREASING VOLTAGE AS VIEWED FROM ROTOR END	
SINGLE PHASE	240	50/60	0-240	28	6.7	CW	2-4	2-3
			0-280	28	7.8	CCW	4-2	4-3
	120	50/60	0-280	28-12#	3.4 ‡	CW	2-5	2-3
			0-280	V.D.		CCW	4-1	4-3

UNLESS OTHERWISE SPECIFIED, TOLERANCE IS # DECIMALS .XX .01 .12 .002 ANGLES 1° DRAFT 1-1/2° UNITS IN [mm] MATERIAL: ALL DIMENSIONS APPLY AFTER PLATING

TITLE: SPEC. CONTROL DRAWING VARIABLE TRANSFORMER TYPE: 5021CT

STACO ENERGY PRODUCTS CO. A COMPONENTS CORPORATION OF AMERICA COMPANY DAYTON, OHIO U.S.A.

DRAWN BY: TIM RAU DATE: 4/18/00 FIRST USED ON: DO NOT SCALE DWG. CUSTOMER APPROVAL: DATE: CHECKER: DATE: WEIGHT APPROX. 57 LBS CODE IDENT. NO. 83008 DWG. NO. 031-7415 ENGINEER: DATE: SCALE: .5=1 SHEET 1 OF 1