

Go to VARIAC.com
to purchase and for
technical support.
Made in the USA

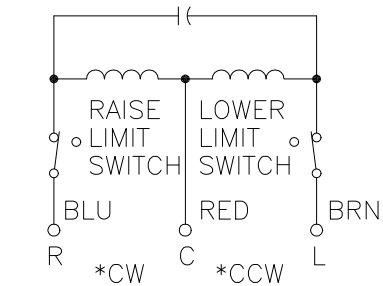
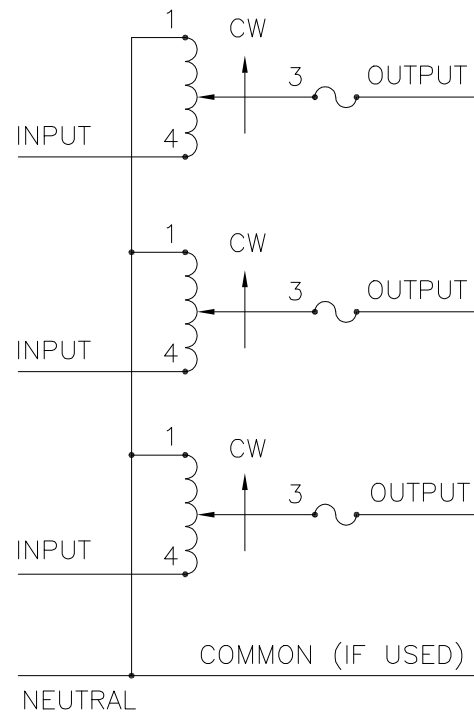
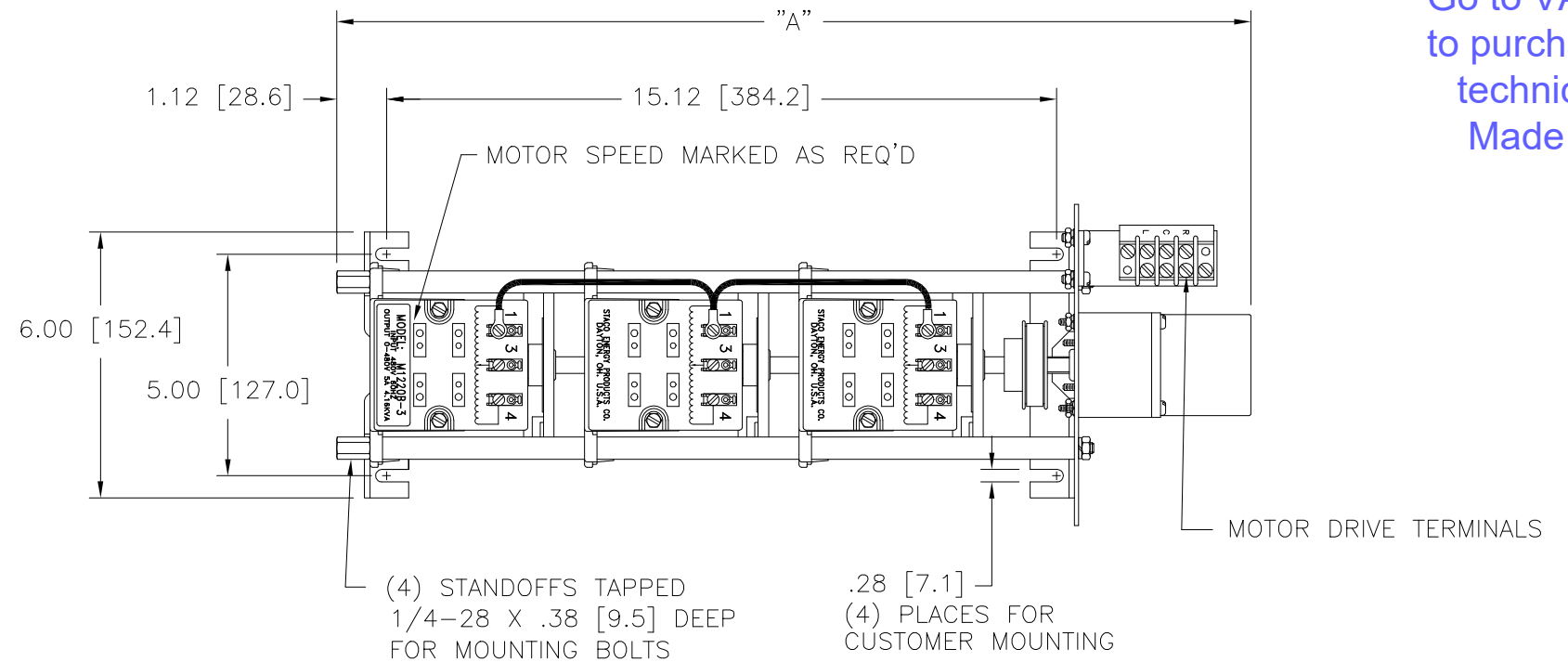
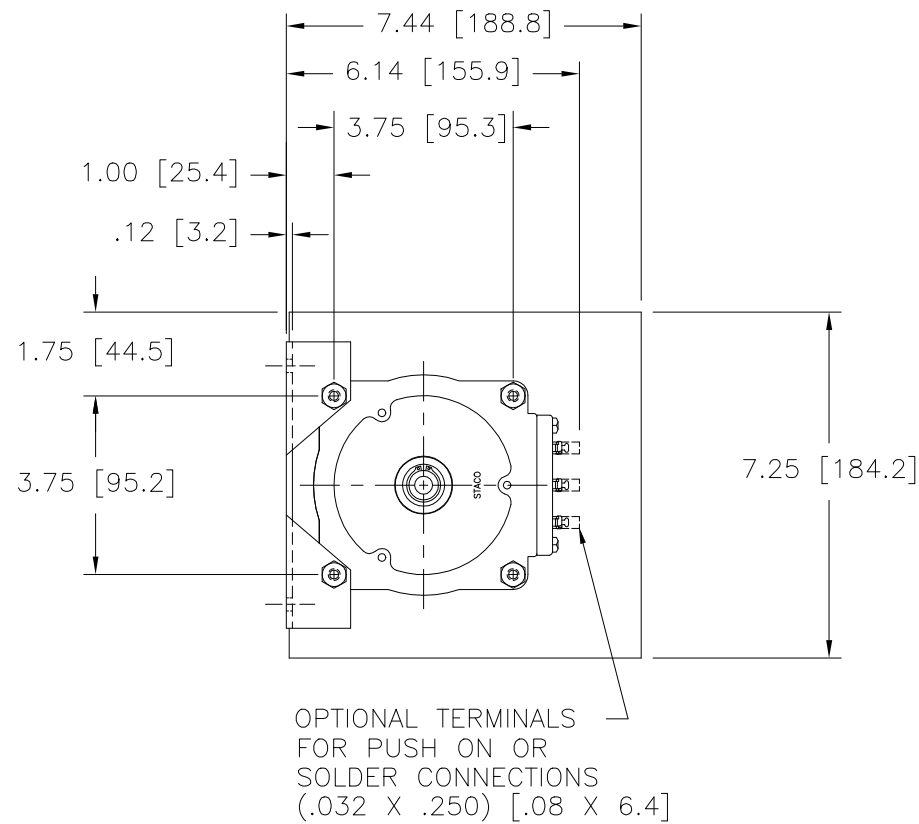

MOTOR CIRCUIT
120V, 50/60 HZ
* ROTATION AS VIEWED FROM MOTOR END
MOTOR SPEED: SEE CHART

- ++ LINE TO LINE VOLTAGE
- + MOTOR DRIVEN UNITS USE TERMINAL CONNECTIONS FOR CCW INCREASING VOLTAGE, AS VIEWED FROM BASE END.
- π IF GANGED UNITS ARE USED IN A SYSTEM THAT ORDINARILY HAS A COMMON NEUTRAL OR GROUND BETWEEN SOURCE AND LOAD, THE NEUTRAL OR GROUND MUST BE CONNECTED TO THE COMMON TERMINALS OF THE VARIABLE TRANSFORMER ASSEMBLY. IF THE SYSTEM HAS NO NEUTRAL, THE LOAD MUST BE BALANCED OR THE TRANSFORMERS WILL BE DAMAGED.
- JUMPER PROVIDED IN THE STANDARD COMMON POSITION AND SHOULD BE MOVED OR REMOVED AS REQUIRED.

SCHEMATIC
FUSE RECOMMENDED BUT NOT SUPPLIED

SPEED (SECONDS)	MODEL NUMBER	DIM "A"
5	5M1220B-3	20.25 [514.2]
15	15M1220B-3	20.25 [514.2]
30	30M1220B-3	20.64 [524.2]
60	60M1220B-3	20.64 [524.2]

WIRING	INPUT		OUTPUT				SHAFT ROTATION TO INCREASE VOLTAGE	TERMINAL CONNECTIONS			
	VOLTS	HERTZ	VOLTS	CONSTANT CURRENT LOAD		CONSTANT IMPEDANCE LOAD		FOR INCREASING VOLTAGE AS VIEWED FROM BASE END +			
				MAX. AMPS	MAX. KVA	MAX. AMPS		MAX. KVA	INPUT	JUMPER ■	OUTPUT
THREE PHASE WYE π	480 ++	60	0-480	5.0	4.16	7.0	5.82	CW	1-1-1	4-4-4	3-3-3
								CCW	4-4-4	1-1-1	3-3-3

UNLESS OTHERWISE SPECIFIED, TOLERANCE IS # DECIMALS .005 HOLES .002 ANGLES 1° DRAFT 1-1/2° UNITS IN [mm]

MATERIAL: ALL DIMENSIONS APPLY AFTER PLATING

TITLE: SPEC. CONTROL DRAWING
MOTORIZED VARIABLE XFMR
MODEL: M1220B-3

DRAWN BY	DATE	FIRST USED ON	DO NOT SCALE DWG.	CUSTOMER APPROVAL	DATE
S.A. SMITH	9/26/97				
CHECKER	DATE	WEIGHT APPROX.	CODE IDENT. NO.	DWG. NO.	DWG. NO.
		38.50 LBS	83008	D	031-3420
ENGINEER	DATE	SCALE	SHEET 1 OF 1		
		.50=1			

STACO ENERGY PRODUCTS CO. A COMPONENTS CORPORATION OF AMERICA COMPANY DAYTON, OHIO U.S.A.