

Go to VARIAC.com to purchase and for technical support. Made in the USA

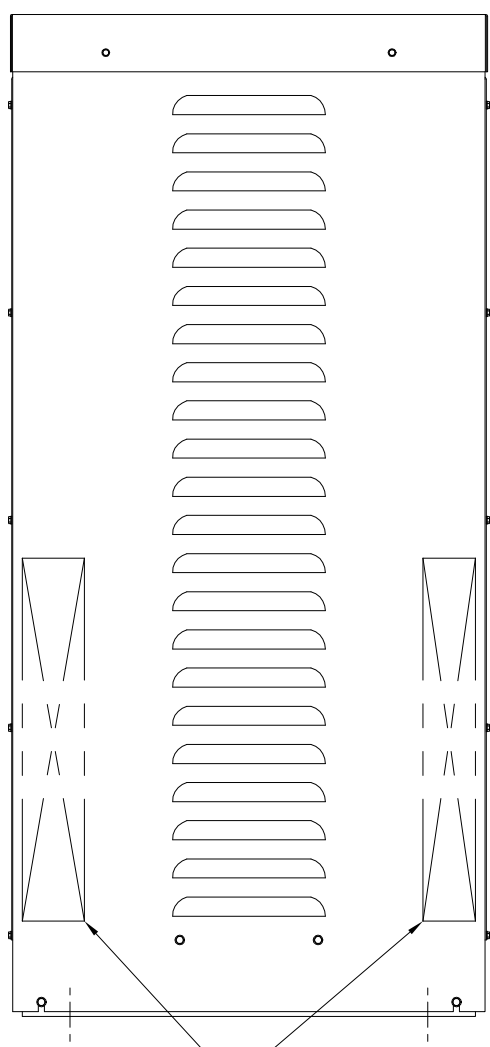
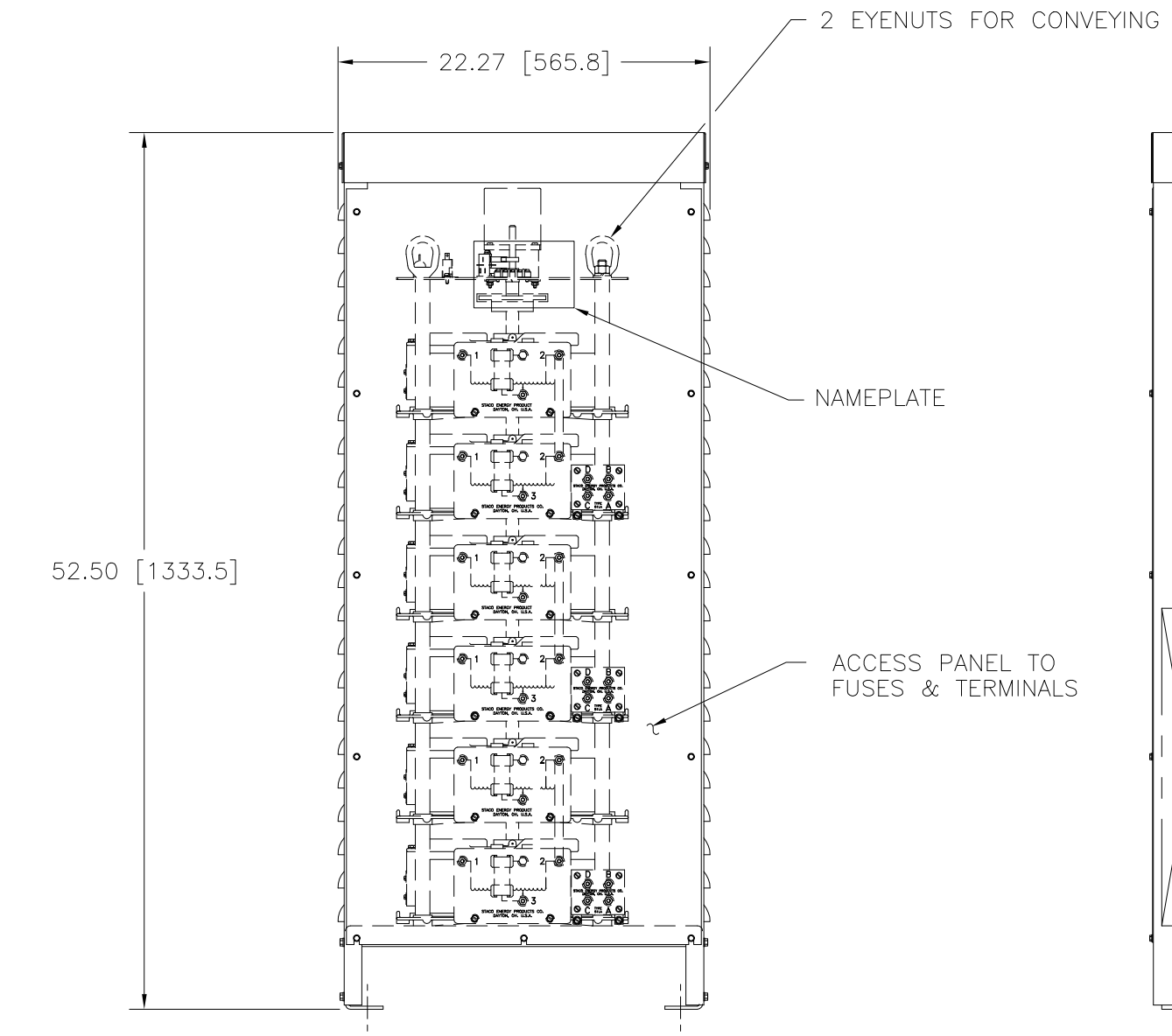
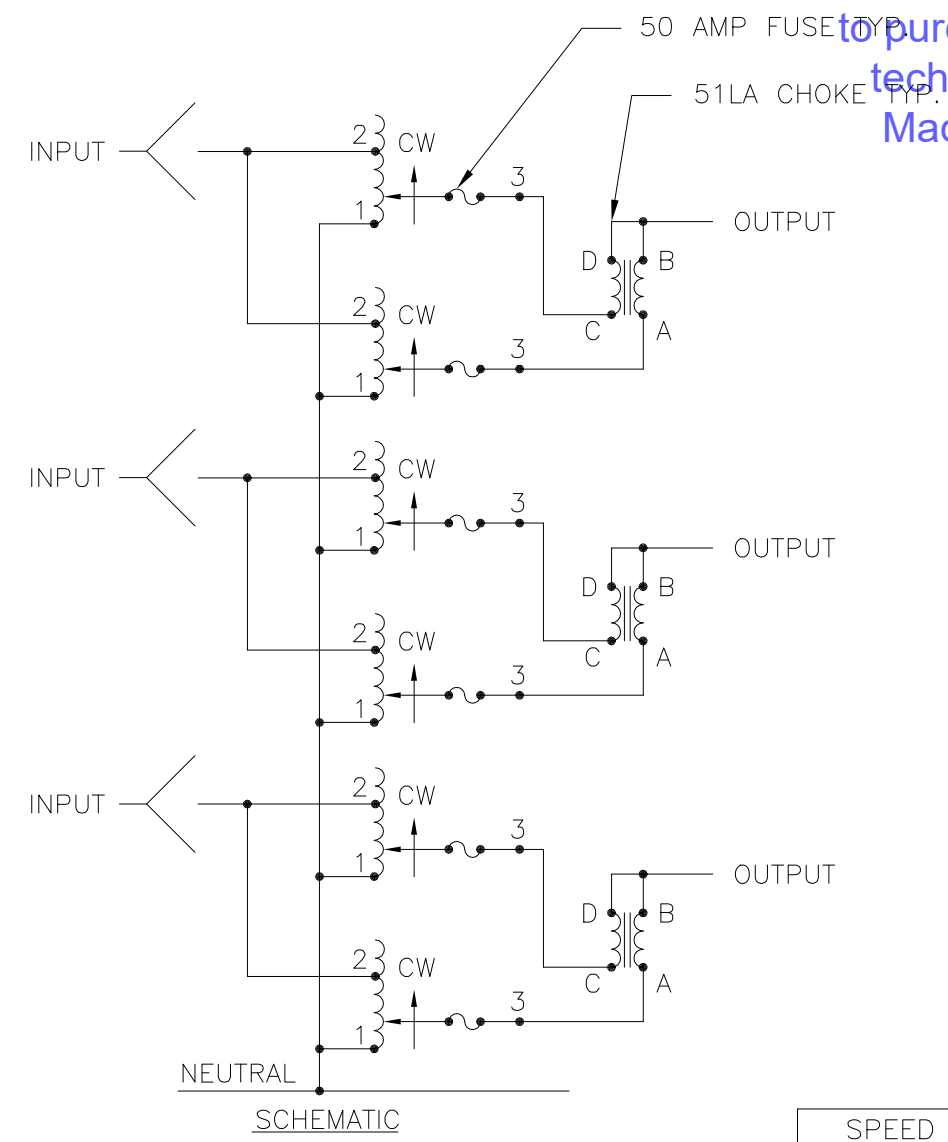
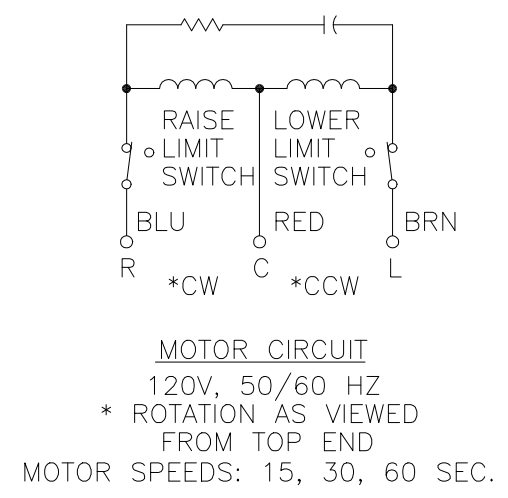
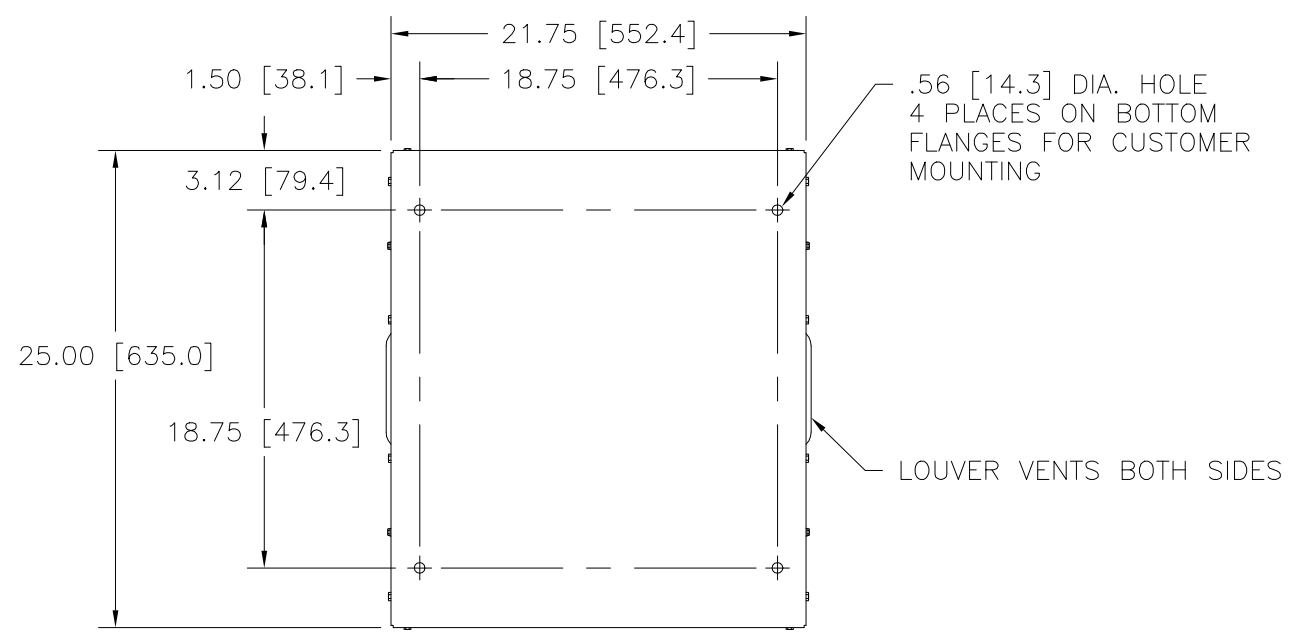

SPEED (SECONDS)	MODEL NUMBER
15	15M5011E-6Y
30	30M5011E-6Y
60	60M5011E-6Y

WIRING	INPUT		OUTPUT			SHAFT ROTATION FOR VOLTAGE INCREASE	TERMINAL CONNECTIONS FOR INCREASING VOLTAGE AS VIEWED FROM TOP	
	VOLTS	HERTZ	VOLTS	CONSTANT CURRENT LOAD			INPUT	OUTPUT
				MAX. AMPS	MAX. KVA			
THREE PHASE WYE	240	60	0-280	100	48.5	CW	2-2-2	B-B-B

UNLESS OTHERWISE SPECIFIED, TOLERANCE IS # DECIMALS .XX .XXX .005 HOLES .12 .0008 .03 ANGLES 1° DRAFT 1-1/2° UNITS IN [mm]

TITLE: SPECIFICATION CONTROL DRAWING
 MOTORIZED VARIABLE TRANSFORMER
 15, 30 & 60M5011E-6Y

MATERIAL: ALL DIMENSIONS APPLY AFTER PLATING

DATE: 12/14/95
 DRAWN BY: TIM RAU
 CHECKER: DATE
 ENGINEER: DATE

DO NOT SCALE DWG.
 WEIGHT APPROX.
 SCALE: .2=1

CUSTOMER APPROVAL: DATE
 DWG. NO. 031-6961
 SHEET 1 OF 1

STACO ENERGY PRODUCTS CO. DAYTON, OHIO U.S.A.

RECOMMENDED AREAS FOR CONDUIT ENTRY