

RECOMMENDED AREAS FOR CONDUIT ENTRY

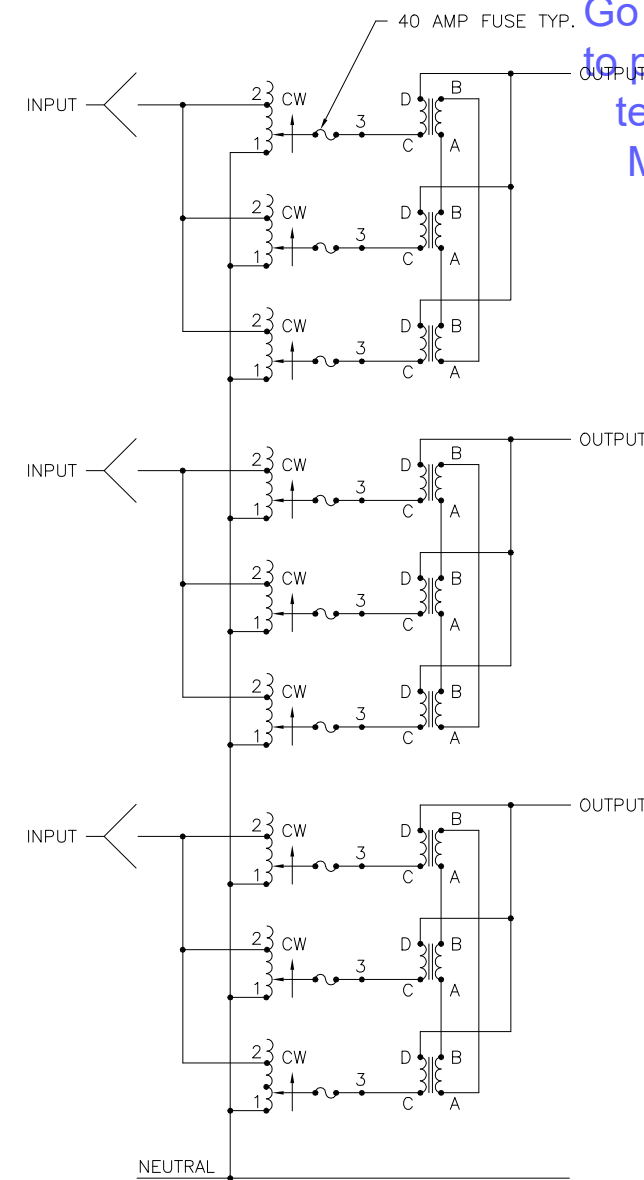
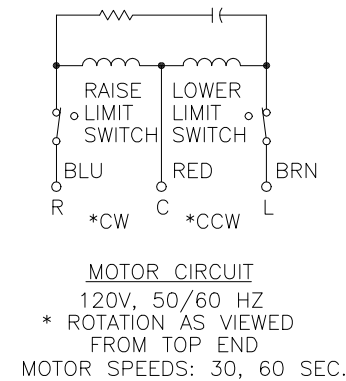

SCHMATIC

Go to VARIAC.com to purchase and for technical support. Made in the USA

SPEED (SECONDS)	MODEL NUMBER
30	30M5011E-9Y
60	60M5011E-9Y

WIRING	INPUT		OUTPUT		SHAFT ROTATION FOR VOLTAGE INCREASE	TERMINAL CONNECTIONS FOR INCREASING VOLTAGE AS VIEWED FROM TOP		
	VOLTS	HERTZ	VOLTS	CONSTANT CURRENT LOAD		INPUT	OUTPUT	
				MAX. AMPS				MAX. KVA
THREE PHASE WYE	240	60	0-280	150	72.5	CW	2-2-2 D-D-D	

UNLESS OTHERWISE SPECIFIED, TOLERANCE IS # DECIMALS .XX .XXX .12 .005 HOLES .03 ANGLES 1° DRAFT 1-1/2° UNITS IN [mm] TITLE: SPECIFICATION CONTROL DRAWING MOTORIZED VARIABLE TRANSFORMER 30 & 60M5011E-9Y

MATERIAL: ALL DIMENSIONS APPLY AFTER PLATING

DRAWN BY: TIM RAU DATE: 12/14/95 FIRST USED ON: DO NOT SCALE DWG. CUSTOMER APPROVAL: DATE:

CHECKER: DATE: WEIGHT APPROX. CODE IDENT. NO. 83008 DWG. NO. 031-7018

ENGINEER: DATE: SCALE: .125=1 SHEET 1 OF 1

STACO ENERGY PRODUCTS CO. DAYTON, OHIO U.S.A.