

Go to [VARIAC.com](http://VARIAC.com)  
 to purchase and for  
 technical support.  
 Made in the USA

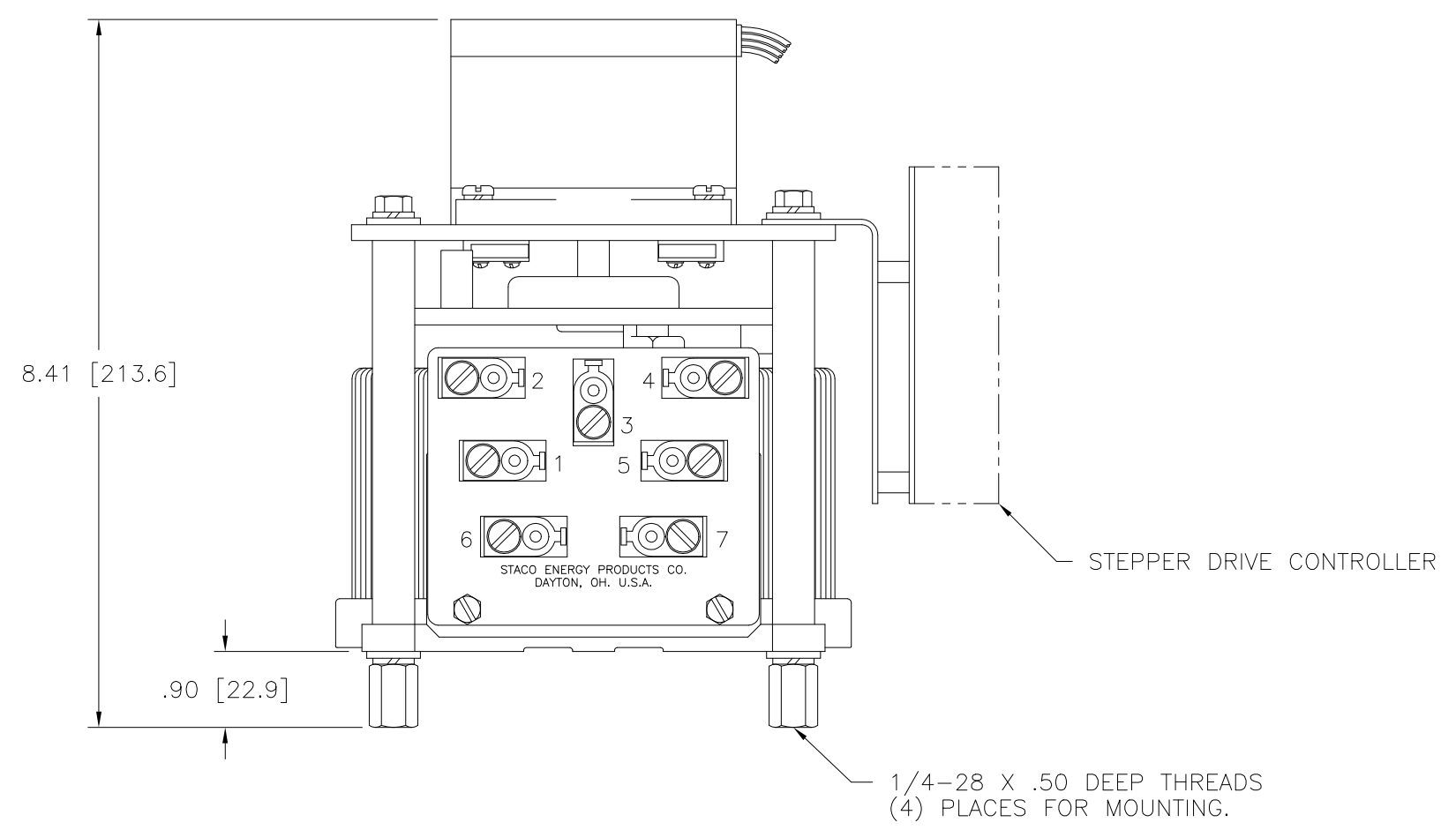
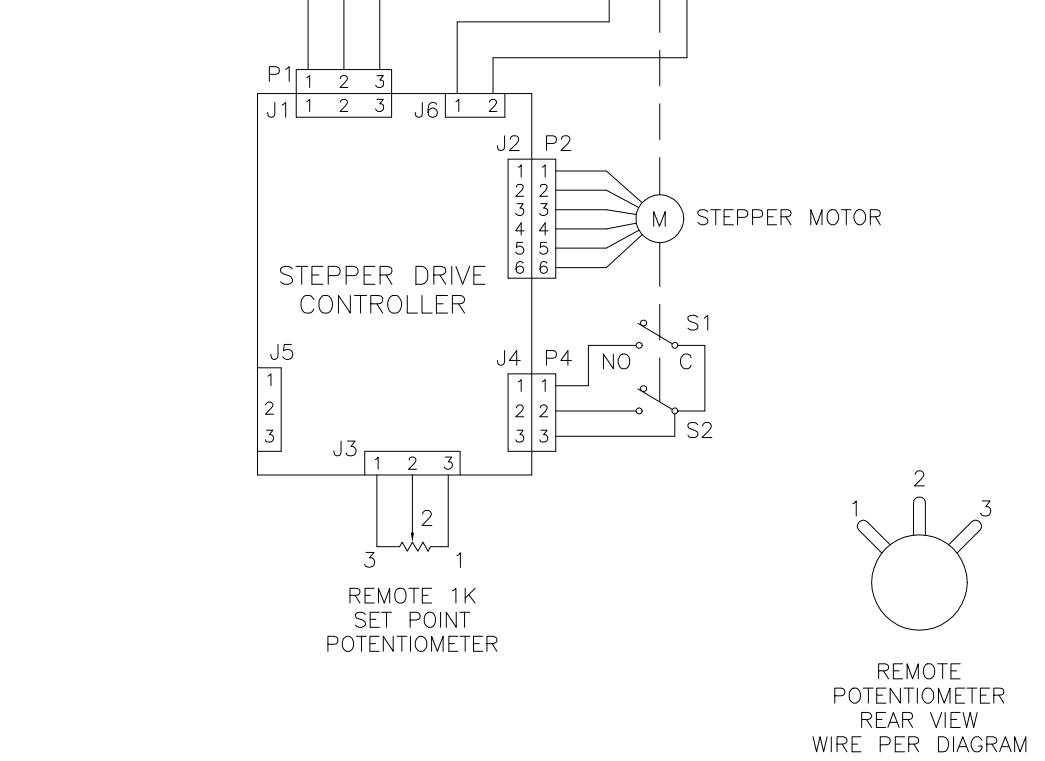
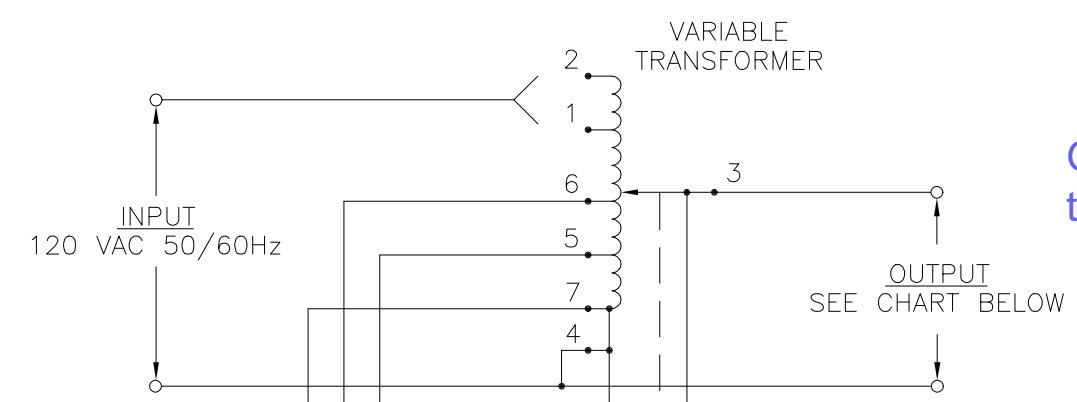
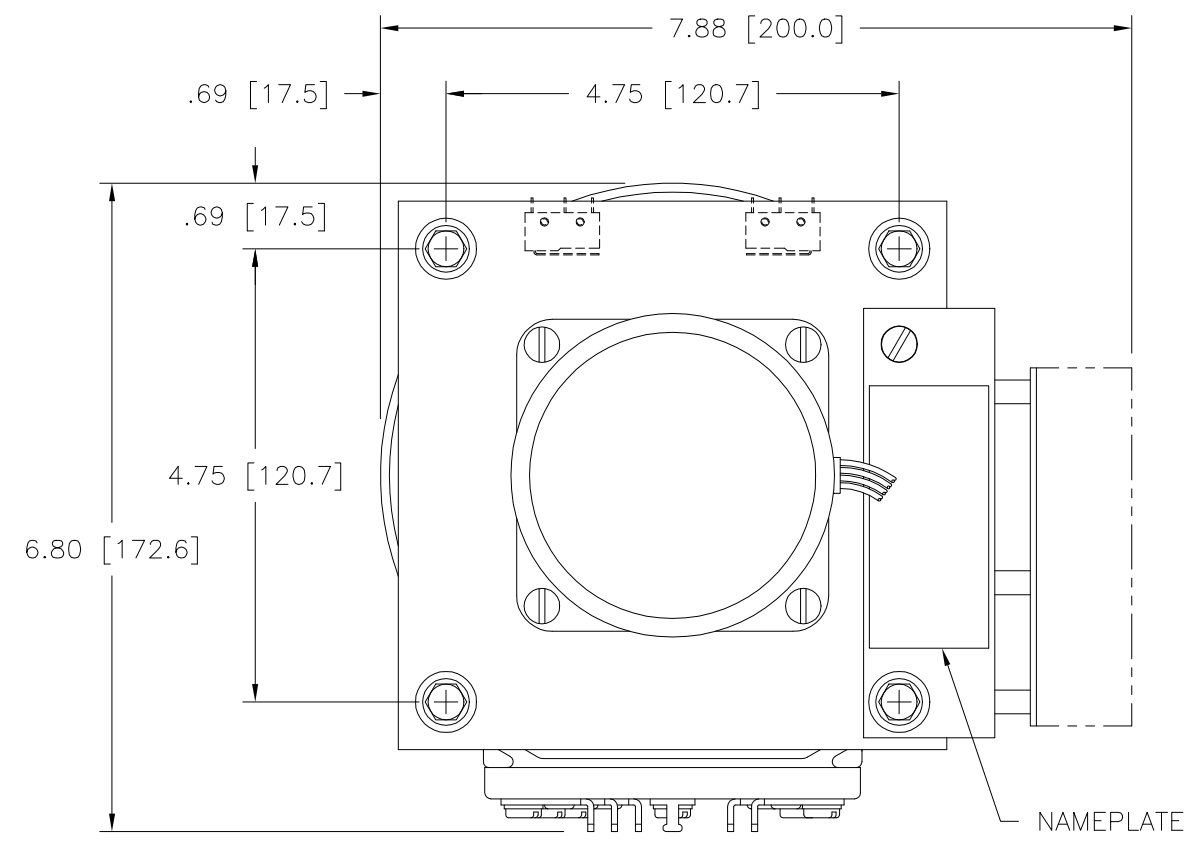

SET POINT ADJUSTMENT:  
 THE OUTPUT SET POINT MAY BE ADJUSTED WITH THE REMOTE 1K POTENTIOMETER PROVIDED OR WITH A 0-5 VDC SIGNAL TO THE J3 CONNECTOR ON THE STEPPER DRIVE CONTROL. MAKE CONNECTIONS TO J3-2(+) & J3-3(-). A NOMINAL +5 VDC SETPOINT SUPPLY IS AVAILABLE AT J3-1 (ADJUSTABLE AT TRIMPOT R22).

SPECIFICATIONS									
WIRING	INPUT		OUTPUT				TERMINAL CONNECTIONS		
	VOLTS	HERTZ	VOLTS	CONSTANT CURRENT LOAD		CONSTANT IMPEDANCE LOAD		INPUT	OUTPUT
SINGLE PHASE	120	50/60	0-120	MAX. AMPS	MAX. KVA	MAX. AMPS	MAX. KVA	2-4	4-3
			0-140	15	1.80	20	2.40	1-4	4-3