

NOTES:
 THE REGULATOR COMPRISES A MOTOR DRIVEN VARIABLE AUTOTRANSFORMER, A BUCK-BOOST FIXED RATIO TRANSFORMER AND A MICROPROCESSOR BASED SOLID STATE CONTROL UNIT THAT AUTOMATICALLY POSITIONS THE AUTOTRANSFORMER TO HOLD THE OUTPUT VOLTAGE CONSTANT.

SPECIFICATIONS:
 WAVEFORM DISTORTION — — — — — ZERO
 FREQUENCY RANGE — — — — — 47Hz TO 63Hz
 ACCURACY — — — — — ±1.0% #
 INTERNAL IMPEDANCE — — — — — EXTREMELY LOW
 PHASE SHIFT — — — — — NEGLIGIBLE
 EFFICIENCY — — — — — APPROXIMATELY 98%
 TEMPERATURE RANGE — — — — — 0°C (32°F) TO +50°C (122°F)

CONTROLS:
 VOLTAGE METER: AN ANALOG 0-300 VAC METER IS PROVIDED TO READ THE OUTPUT VOLTAGE.

SET POINT: THIS POTENTIOMETER CONTROL IS ROTATED CLOCKWISE TO INCREASE THE OUTPUT VOLTAGE SET POINT AND COUNTERCLOCKWISE TO DECREASE THE OUTPUT VOLTAGE SET POINT.

CONTROL CIRCUIT SWITCH: THIS ILLUMINATED PUSHBUTTON SWITCH IS PROVIDED TO INDICATE THAT THE CONTROL UNIT IS OPERATING WHEN ILLUMINATED AND AS A RESET SWITCH FOR THE MICROPROCESSOR.

REGULATION IS ±0.5% FOR +5% THRU -9% OF THE INPUT VOLTAGE RANGE.

* AT NOMINAL OUTPUT VOLTAGE. INPUT VOLTAGE RANGE (+6% TO -10%) SHIFTS PROPORTIONALLY WITH OUTPUT VOLTAGE SETTINGS.

++ INPUT RANGE IN VOLTS DIVIDED BY THE MOTOR DRIVE TRAVEL TIME IN SECONDS.

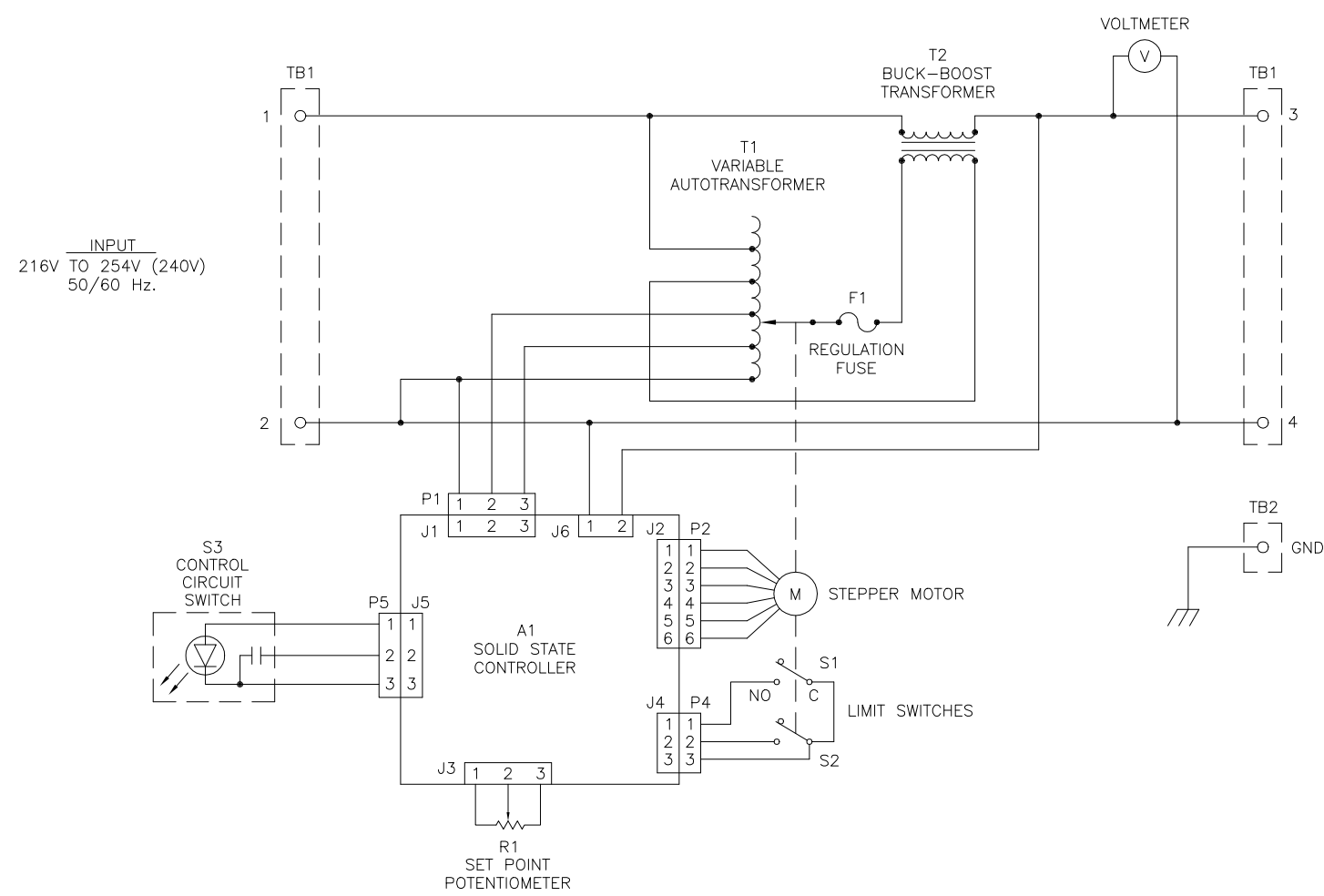

SINGLE PHASE 50/60Hz				
NOMINAL OUTPUT VOLTAGE	INPUT VOLTAGE RANGE*	MAXIMUM OUTPUT AMPERES	RATED OUTPUT (KVA)	CORRECTION RATE (VOLTS/SECOND)++
240	216-254	62.5	15	38

UNLESS OTHERWISE SPECIFIED, TOLERANCE IS # DECIMALS .XX .XXX .012 .002 .1° .005 .1° 1-1/2° UNITS IN [mm]

TITLE: SPEC. CONTROL DRAWING AUTO. VOLTAGE REGULATOR MODEL: SVR-24HBSN015R

MATERIAL: ALL DIMENSIONS APPLY AFTER PLATING

STACO ENERGY PRODUCTS CO. DAYTON, OHIO U.S.A.

DRAWN BY: S.A. SMITH DATE: 6/20/96 FIRST USED ON: DO NOT SCALE DWG. CUSTOMER APPROVAL: DATE:

CHECKER: DATE: WEIGHT APPROX. CODE IDENT. NO. 83008 DWG. NO. 095-1890

ENGINEER: DATE: SCALE: .50=1 SHEET 1 OF 1