

NOTES:

THE REGULATOR COMPRISES A MOTOR DRIVEN VARIABLE AUTOTRANSFORMER, A BUCK-BOOST FIXED RATIO TRANSFORMER AND A MICROPROCESSOR BASED SOLID STATE CONTROL UNIT THAT AUTOMATICALLY POSITIONS THE AUTOTRANSFORMER TO HOLD THE OUTPUT VOLTAGE CONSTANT.

SPECIFICATIONS:

WAVEFORM DISTORTION — — — — — ZERO
 FREQUENCY RANGE — — — — — 47Hz TO 63Hz
 ACCURACY — — — — — ±1.0% #
 INTERNAL IMPEDANCE — — — — — EXTREMELY LOW
 PHASE SHIFT — — — — — NEGLIGIBLE
 EFFICIENCY — — — — — APPROXIMATELY 98%
 TEMPERATURE RANGE — — — — — 0°C (32°F) TO +50°C (122°F)

CONTROLS:

VOLTAGE METER: AN ANALOG 0-300 VAC METER IS PROVIDED TO READ THE OUTPUT VOLTAGE.

SET POINT: THIS POTENTIOMETER CONTROL IS ROTATED CLOCKWISE TO INCREASE THE OUTPUT VOLTAGE SET POINT AND COUNTERCLOCKWISE TO DECREASE THE OUTPUT VOLTAGE SET POINT.

CONTROL CIRCUIT SWITCH: THIS ILLUMINATED PUSHBUTTON SWITCH IS PROVIDED TO INDICATE THAT THE CONTROL UNIT IS OPERATING WHEN ILLUMINATED AND AS A RESET SWITCH FOR THE MICROPROCESSOR.

REGULATION IS ±0.5% FOR +6% THRU -16% OF THE INPUT VOLTAGE RANGE.

* AT NOMINAL OUTPUT VOLTAGE. INPUT VOLTAGE RANGE (+7% TO -17%) SHIFTS PROPORTIONALLY WITH OUTPUT VOLTAGE SETTINGS.

++ INPUT RANGE IN VOLTS DIVIDED BY THE MOTOR DRIVE TRAVEL TIME IN SECONDS.

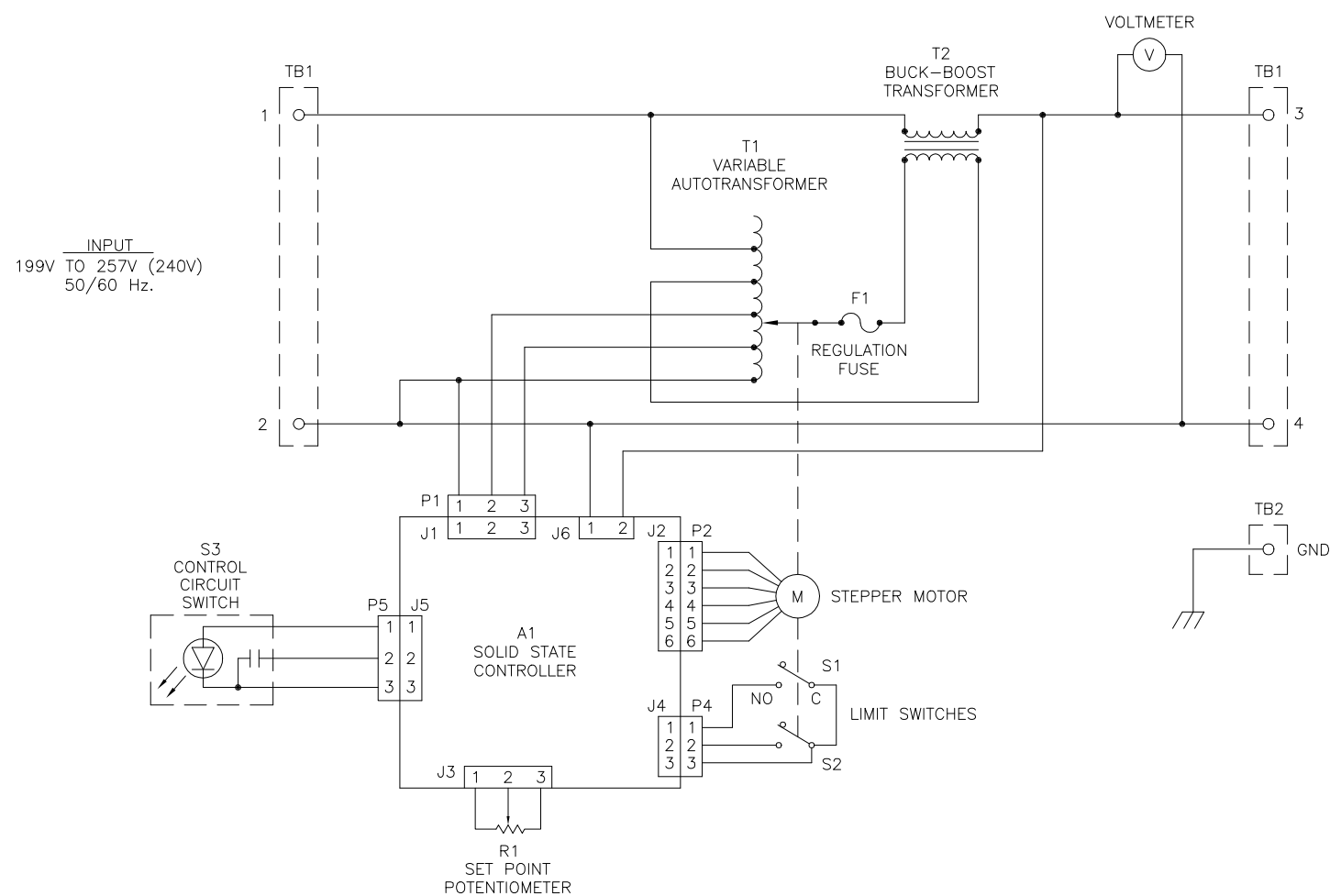

| SINGLE PHASE 50/60Hz | | | | |
|------------------------|----------------------|------------------------|--------------------|----------------------------------|
| NOMINAL OUTPUT VOLTAGE | INPUT VOLTAGE RANGE* | MAXIMUM OUTPUT AMPERES | RATED OUTPUT (KVA) | CORRECTION RATE (VOLTS/SECOND)++ |
| 240 | 199-257 | 31.2 | 7.5 | 58 |

| | | | | | | |
|---|-------|------------------------------------|--------|------------------------------|--|---|
| UNLESS OTHERWISE SPECIFIED, TOLERANCE IS # | | UNITS | | TITLE: SPEC. CONTROL DRAWING | | STACO ENERGY PRODUCTS CO. DAYTON, OHIO U.S.A. |
| DECIMALS | Holes | ANGLES | DRAFT | IN [mm] | | |
| .XX | .125 | 1° | 1-1/2° | | | |
| MATERIAL: | | ALL DIMENSIONS APPLY AFTER PLATING | | DRAWN BY S.A. SMITH | | DATE 6/20/96 |
| The information and design disclosed herein was originated by and is the property of STACO ENERGY PRODUCTS CO., which reserves all patent, proprietary, design, manufacturing, reproduction, use and sale rights thereto, and to any article disclosed therein except to the extent rights are expressly granted to others. The foregoing does not apply to vendor proprietary parts. | | CHECKER | | DATE | | SCALE .50=1 |
| ENGINEER | | DATE | | WEIGHT APPROX. | | CODE IDENT. NO. 83008 |
| | | | | SHEET 1 OF 1 | | DWG. NO. 095-1887 |