

Go to VARIAC.com
to purchase and for
technical support.
Made in the USA

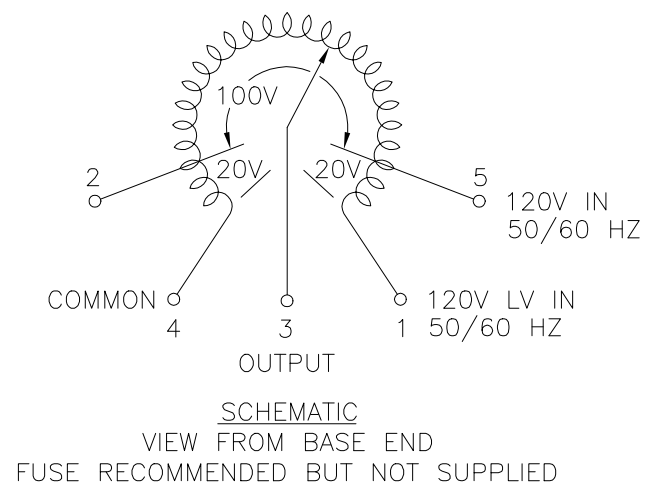

| SPECIFICATIONS | | | | | | | | | | | |
|----------------|-------|-------|--------|-----------------------|----------|-------------------------|------------------------------------|--|-------|--------|--------|
| WIRING | INPUT | | OUTPUT | | | | SHAFT ROTATION TO INCREASE VOLTAGE | TERMINAL CONNECTIONS | | | |
| | VOLTS | HERTZ | VOLTS | CONSTANT CURRENT LOAD | | CONSTANT IMPEDANCE LOAD | | FOR INCREASING VOLTAGE AS VIEWED FROM BASE END | | | |
| | | | | MAX. AMPS | MAX. KVA | MAX. AMPS | | MAX. KVA | INPUT | JUMPER | OUTPUT |
| SINGLE PHASE | 120 | 50/60 | 0-120 | 10 | 1.2 | 13 | 1.56 | CW | 1-4 | --- | 4-3 |
| | | | 0-140 | 10 | 1.4 | --- | --- | CCW | 1-4 | --- | 1-3 |
| | | | | | | | | CW | 4-5 | --- | 4-3 |
| | | | | | | | | CCW | 1-2 | --- | 1-3 |

| | | | | | | | | | | | |
|--|-----------|--------|-------|------------------------------------|----------------------|------------------------------|-------------------|--|--|--|--|
| UNLESS OTHERWISE SPECIFIED, TOLERANCE IS # | | | | UNITS | | TITLE: SPEC. CONTROL DRAWING | | | | | |
| DECIMALS | Holes | ANGLES | DRAFT | IN [mm] | | VARIABLE TRANSFORMER | | | | | |
| .XX | .0005-.03 | .002 | 1° | 1-1/2" | | MODEL: 1010B | | | | | |
| XXX | .005 | | | ALL DIMENSIONS APPLY AFTER PLATING | | MATERIAL: | | | | | |
| DRAWN BY S.A. SMITH | | | | DATE 9/16/97 | FIRST USED ON | DO NOT SCALE DWG. | CUSTOMER APPROVAL | | | | |
| CHECKER | | | | DATE | WEIGHT APPROX. 9 LBS | CODE IDENT. NO. 83008 | DATE | | | | |
| ENGINEER | | | | DATE | SCALE 1=1 | SHEET 1 OF 1 | DWG. NO. 031-1605 | | | | |

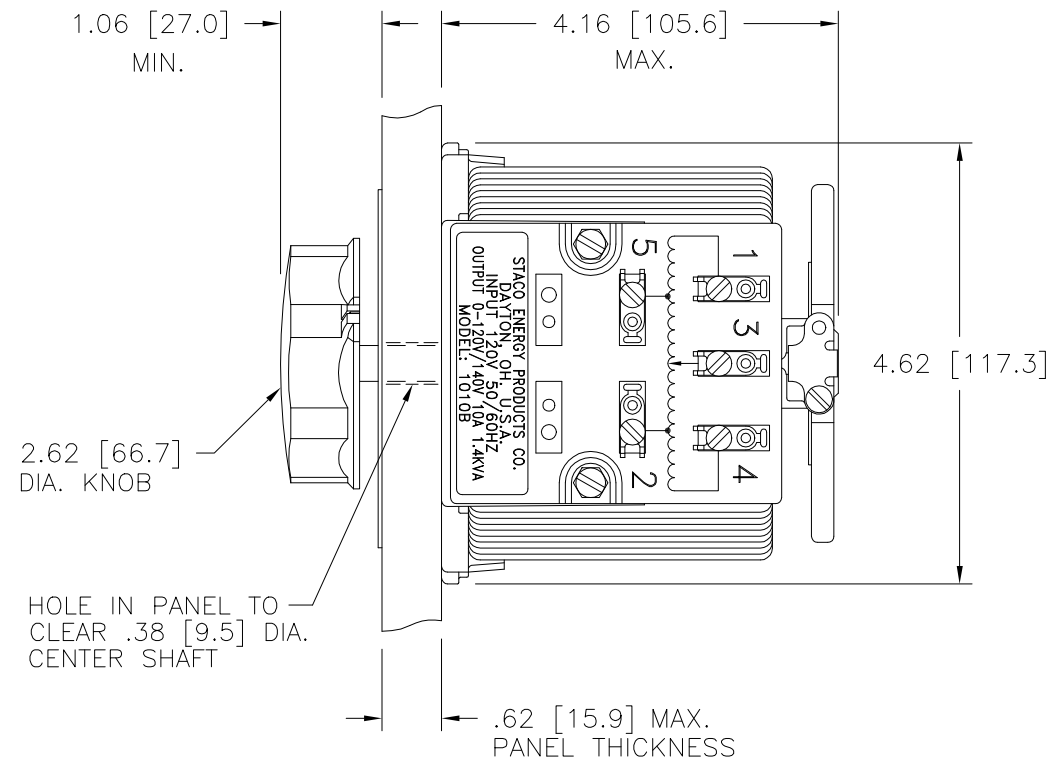
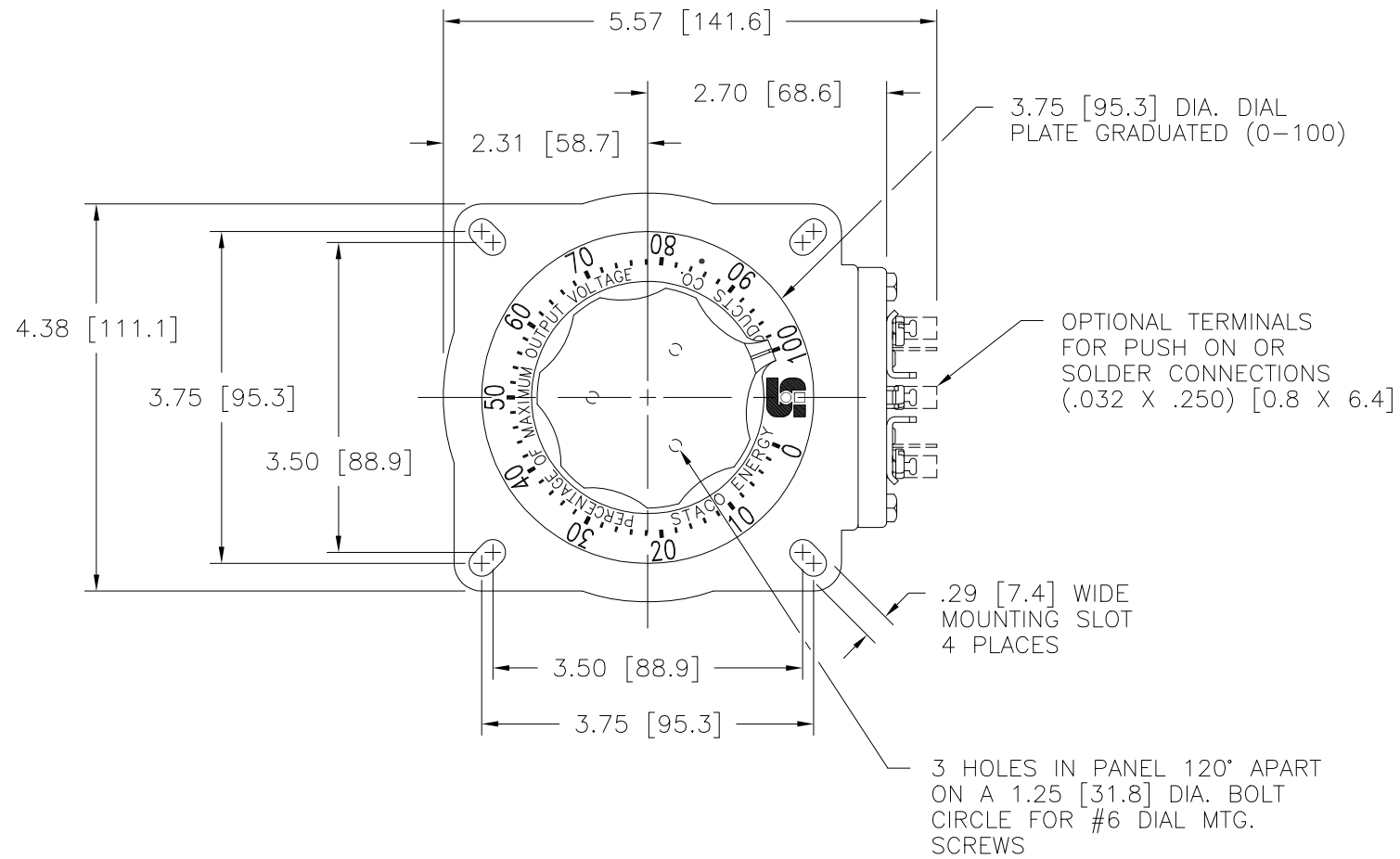