

SCHEMATIC
VIEWED FROM BASE END

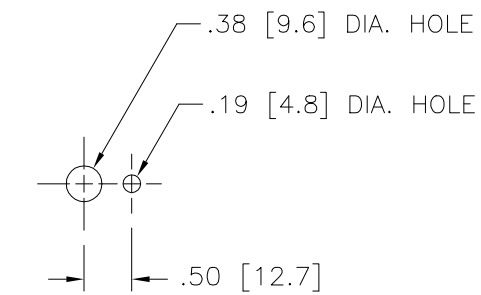

PANEL MTG. DETAIL

SPECIFICATIONS											
WIRING	INPUT		OUTPUT				SHAFT ROTATION TO INCREASE VOLTAGE	TERMINAL CONNECTIONS			
	VOLTS	HERTZ	VOLTS	CONSTANT CURRENT LOAD		CONSTANT IMPEDANCE LOAD		FOR INCREASING VOLTAGE AS VIEWED FROM BASE END			
				MAX. AMPS	MAX. KVA	MAX. AMPS		MAX. KVA	INPUT	JUMPER	OUTPUT
SINGLE PHASE	120	50/60	0-120	1.75	0.21	2.2	0.26	CW	1-2	---	1-3
		60	0-132	1.75	0.23	---	---	CCW	1-2	---	2-3
								CW	1-4	---	1-3

UNLESS OTHERWISE SPECIFIED, TOLERANCE IS ±				UNITS				TITLE: SPEC. CONTROL DRAWING			
DECIMALS	Holes	ANGLES	DRAFT	IN	MM			SPEC. CONTROL DRAWING			
.XX	.0000	.002	1*					VARIABLE TRANSFORMER			
-.0005								MODEL 171			
MATERIAL:				ALL DIMENSIONS APPLY AFTER PLATING				DRAWN BY S.A. SMITH			
								DATE 1/30/02			
								FIRST USED ON			
								DO NOT SCALE DWG.			
								CHECKER SAS			
								DATE 1/30/02			
								WEIGHT APPROX.			
								SCALE 1/1			
								SHEET 1 OF 1			
								DWG. NO. 031-0101			

