

OPTIONAL TERMINALS FOR PUSH ON OR SOLDER CONNECTIONS (.032 X .250) [0.8 X 6.4]

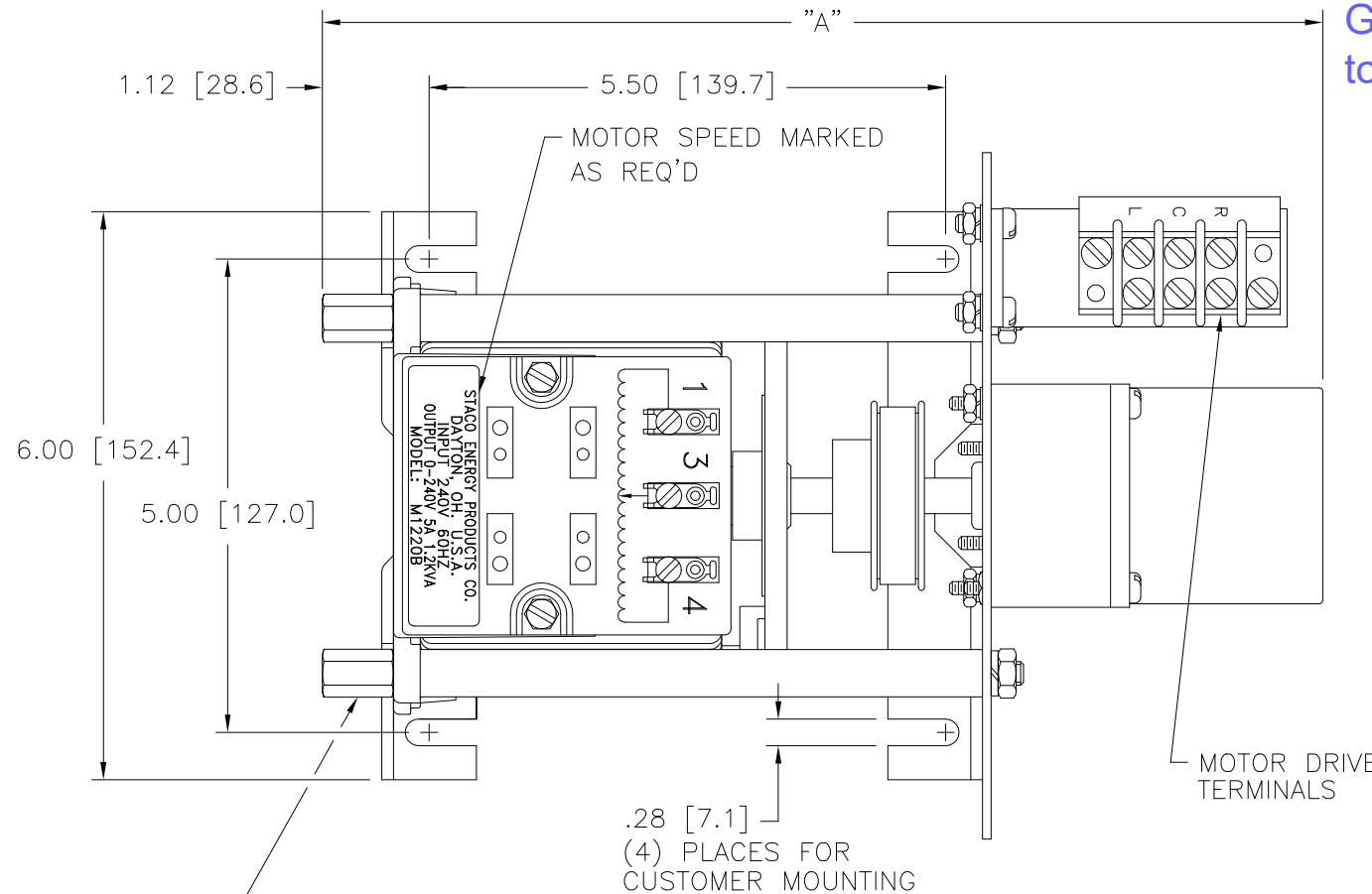

(4) STANDOFFS TAPPED 1/4-28 X .38 [9.5] DEEP FOR MOUNTING BOLTS

Go to VARIAC.com to purchase and for technical support. Made in the USA

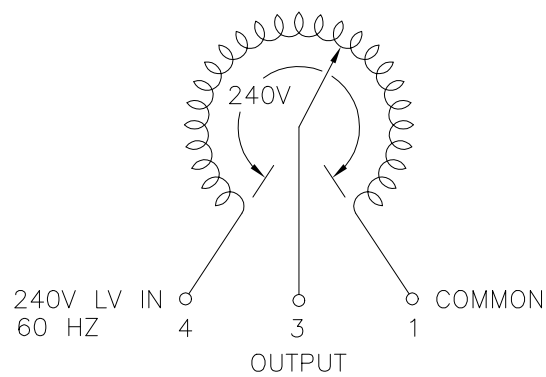

SCHEMATIC VIEW FROM BASE END FUSE RECOMMENDED BUT NOT SUPPLIED

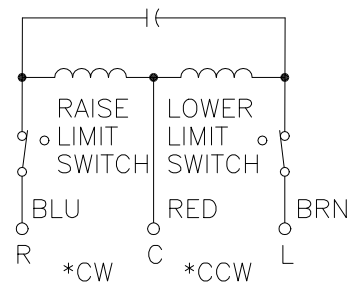

MOTOR CIRCUIT 120V, 50/60 HZ * ROTATION AS VIEWED FROM MOTOR END MOTOR SPEED: SEE CHART

+ MOTOR DRIVEN UNITS USE TERMINAL CONNECTIONS FOR CCW INCREASING VOLTAGE, AS VIEWED FROM BASE END.

SPEED (SECONDS)	MODEL NUMBER	DIM "A"
5	5M1220B	10.56 [268.2]
15	15M1220B	10.56 [268.2]
30	30M1220B	10.95 [278.1]
60	60M1220B	10.95 [278.1]

WIRING	INPUT		OUTPUT				SHAFT ROTATION TO INCREASE VOLTAGE	TERMINAL CONNECTIONS			
	VOLTS	HERTZ	VOLTS	CONSTANT CURRENT LOAD		CONSTANT IMPEDANCE LOAD		FOR INCREASING VOLTAGE AS VIEWED FROM BASE END +			
				MAX. AMPS	MAX. KVA	MAX. AMPS		MAX. KVA	INPUT	JUMPER	OUTPUT
SINGLE PHASE	240	60	0-240	5.0	1.20	7.0	1.68	CW	1-4	---	4-3
								CCW	1-4	---	1-3

UNLESS OTHERWISE SPECIFIED, TOLERANCE IS # DECIMALS HOLES .002 ANGLES DRAFT 1° 1-1/2° UNITS IN [mm]

MATERIAL: ALL DIMENSIONS APPLY AFTER PLATING

TITLE: SPEC. CONTROL DRAWING MOTORIZED VARIABLE XFMR MODEL: M1220B

STACO ENERGY PRODUCTS CO. A COMPONENTS CORPORATION OF AMERICA COMPANY DAYTON, OHIO U.S.A.

DRAWN BY S.A. SMITH	DATE 9/26/97	FIRST USED ON	DO NOT SCALE DWG.	CUSTOMER APPROVAL	DATE
CHECKER	DATE	WEIGHT APPROX. 15.50 LBS	CODE IDENT. NO. 83008	DWG. NO. 031-3360	DWG. SIZE D
ENGINEER	DATE	SCALE 1=1	SHEET 1 OF 1		