

Go to VARIAC.com
to purchase and for
technical support.
Made in the USA

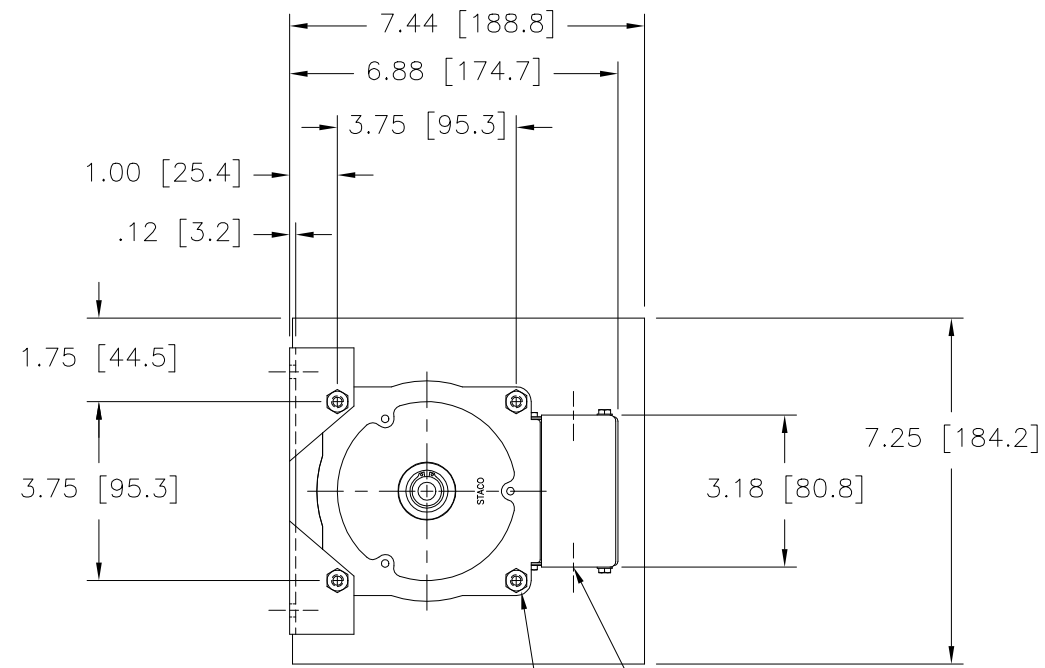

(4) STANDOFFS TAPPED
1/4-28 X .38 [9.5] DEEP
FOR MOUNTING BOLTS

.88 [22.2] DIA. KNOCKOUT
(6) PLACES FOR
WIRING CONNECTIONS

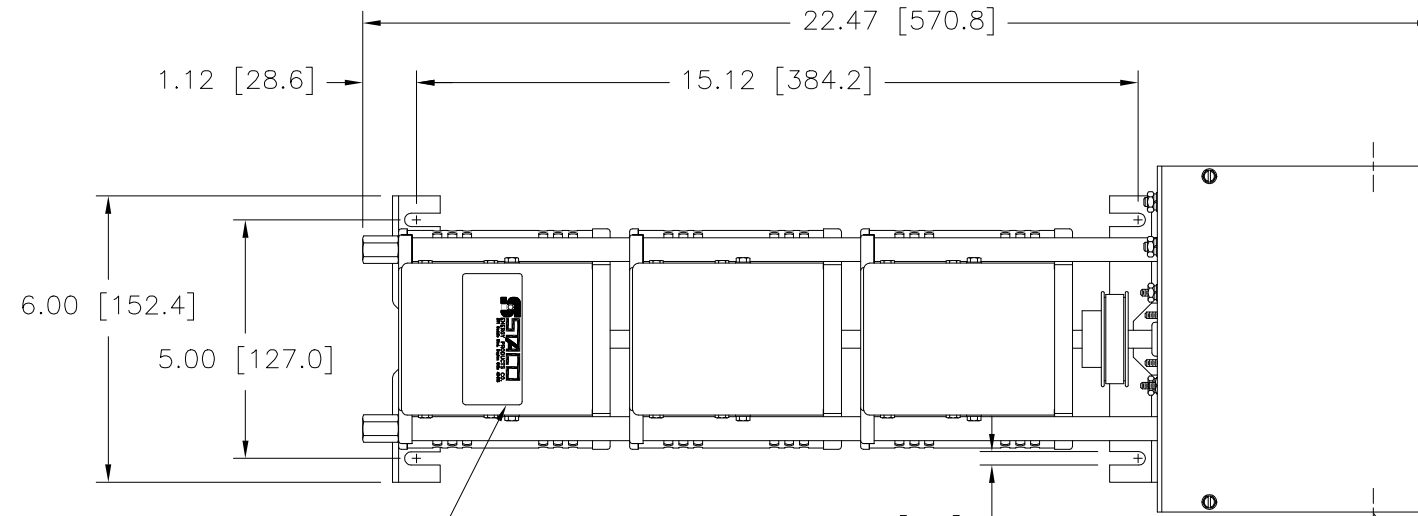

NAMEPLATE

.28 [7.1]
(4) PLACES FOR
CUSTOMER MOUNTING

.88 [22.2] DIA. KNOCKOUT
(4) PLACES FOR
MOTOR CONNECTIONS

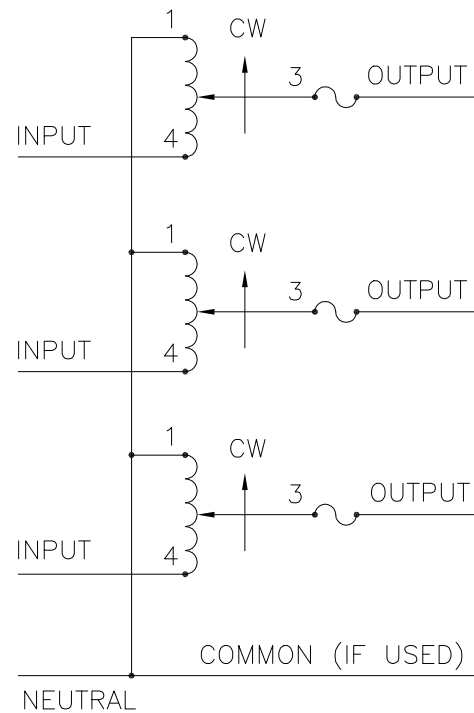

SCHEMATIC

FUSE RECOMMENDED BUT NOT SUPPLIED

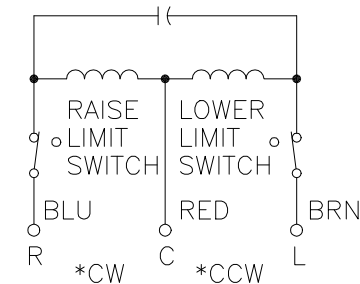

MOTOR CIRCUIT
120V, 50/60 HZ
* ROTATION AS VIEWED
FROM MOTOR END
MOTOR SPEED: SEE CHART

- ++ LINE TO LINE VOLTAGE
- + MOTOR DRIVEN UNITS USE TERMINAL CONNECTIONS FOR CCW INCREASING VOLTAGE, AS VIEWED FROM BASE END.
- π IF GANGED UNITS ARE USED IN A SYSTEM THAT ORDINARILY HAS A COMMON NEUTRAL OR GROUND BETWEEN SOURCE AND LOAD, THE NEUTRAL OR GROUND MUST BE CONNECTED TO THE COMMON TERMINALS OF THE VARIABLE TRANSFORMER ASSEMBLY. IF THE SYSTEM HAS NO NEUTRAL, THE LOAD MUST BE BALANCED OR THE TRANSFORMERS WILL BE DAMAGED.
- JUMPER PROVIDED IN THE STANDARD COMMON POSITION AND SHOULD BE MOVED OR REMOVED AS REQUIRED.

SPEED (SECONDS)	MODEL NUMBER
5	5M1220BCT-3
15	15M1220BCT-3
30	30M1220BCT-3
60	60M1220BCT-3

WIRING	INPUT		OUTPUT				SHAFT ROTATION TO INCREASE VOLTAGE	TERMINAL CONNECTIONS			
	VOLTS	HERTZ	VOLTS	CONSTANT CURRENT LOAD		CONSTANT IMPEDANCE LOAD		FOR INCREASING VOLTAGE AS VIEWED FROM BASE END +			
				MAX. AMPS	MAX. KVA	MAX. AMPS		MAX. KVA	INPUT	JUMPER ■	OUTPUT
THREE PHASE WYE π	480 ++	60	0-480	5.0	4.16	7.0	5.82	CW	1-1-1	4-4-4	3-3-3
								CCW	4-4-4	1-1-1	3-3-3

UNLESS OTHERWISE SPECIFIED, TOLERANCE IS #		UNITS		TITLE: SPEC. CONTROL DRAWING		DRAWN BY		DATE		FIRST USED ON		CUSTOMER APPROVAL		DATE	
DECIMALS	Holes	ANGLES	DRAFT	IN	MM	S.A. SMITH		9/26/97							
.XX	.002	1°	1-1/2°	ALL DIMENSIONS APPLY AFTER PLATING		CHECKER		DATE		WEIGHT APPROX. 42 LBS		CODE IDENT. NO. 83008		DWG. NO. 031-3520	
MATERIAL:						ENGINEER		DATE		SCALE .50=1		SHEET 1 OF 1			



STACO ENERGY PRODUCTS CO.
A COMPONENTS CORPORATION OF AMERICA COMPANY
DAYTON, OHIO U.S.A.