

Go to VARIAC.com
 to purchase and for
 technical support.
 Made in the USA

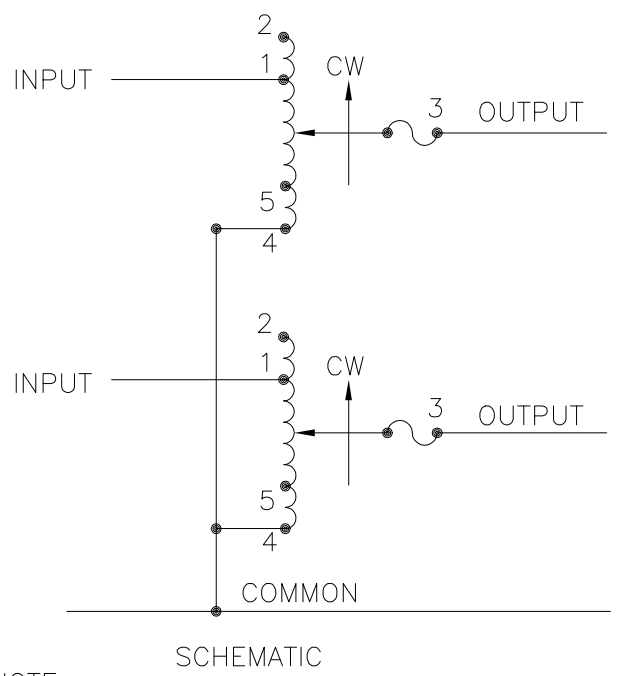

NOTE:
 FUSE RECOMMENDED BUT NOT SUPPLIED

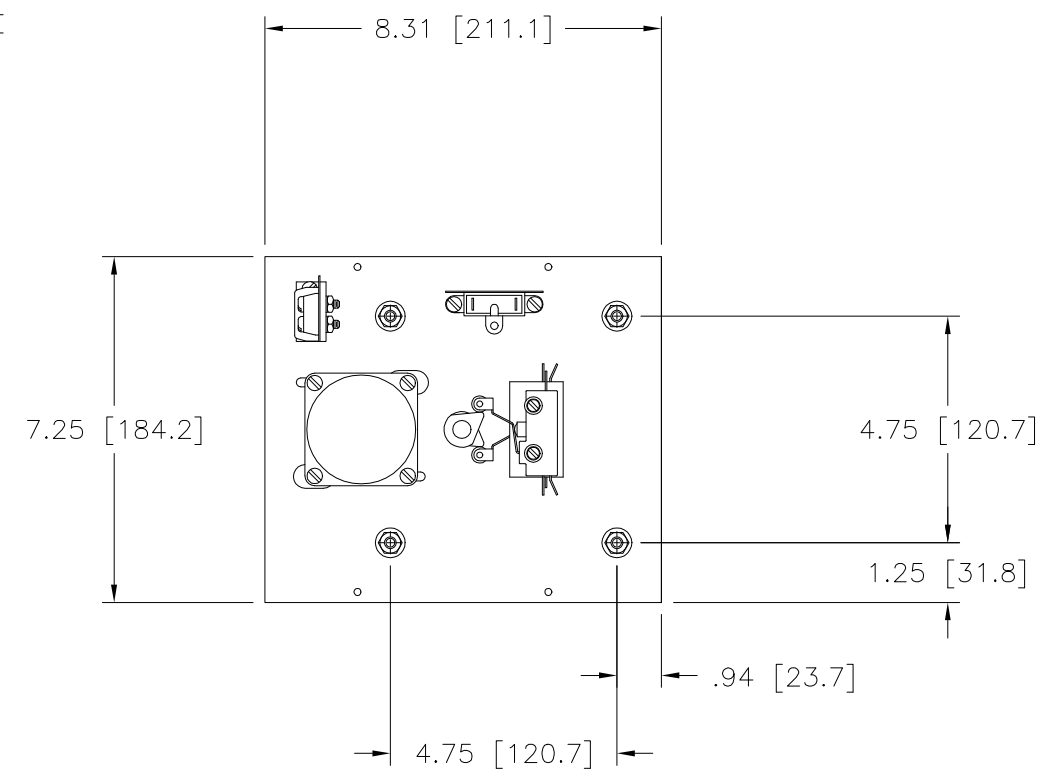
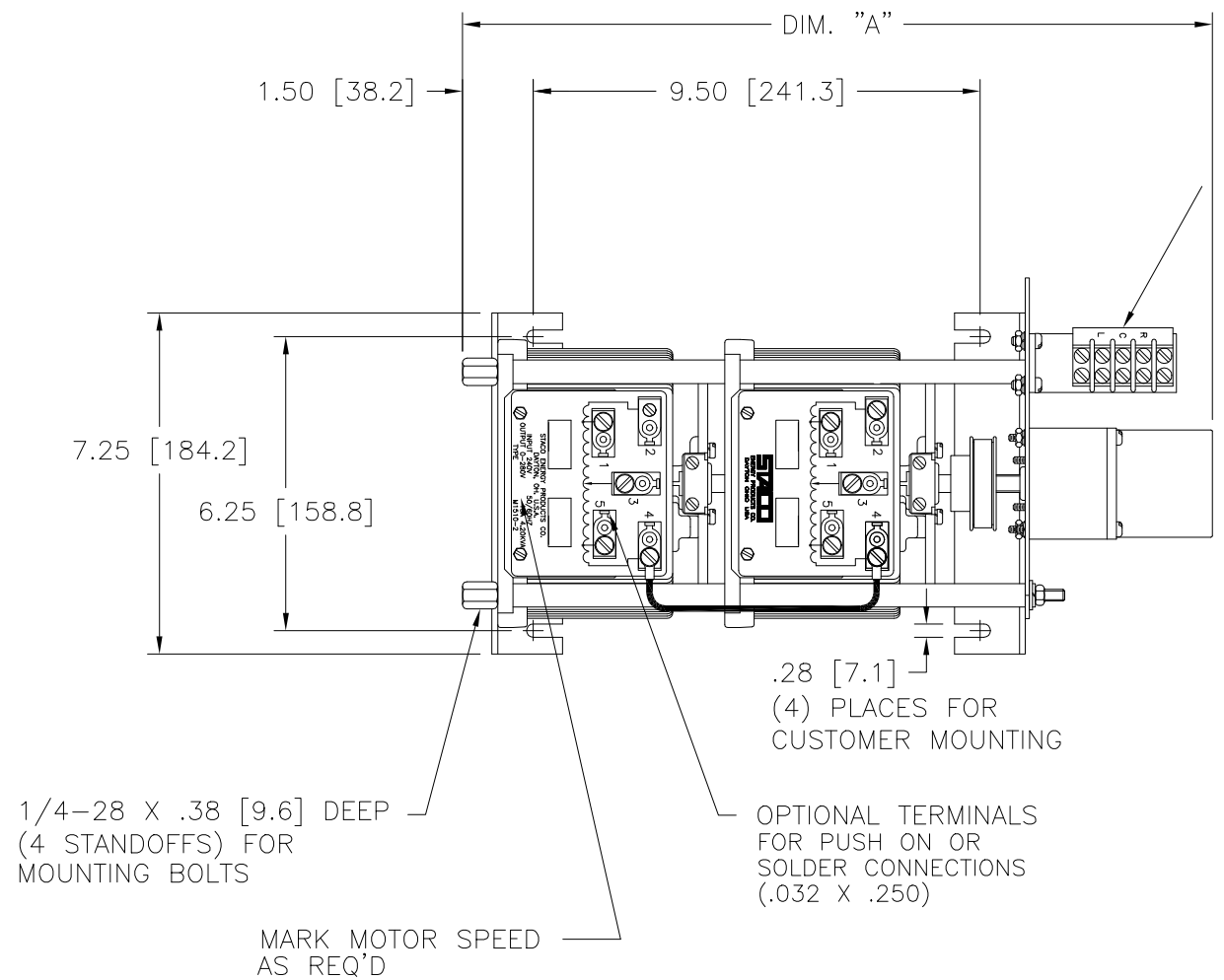
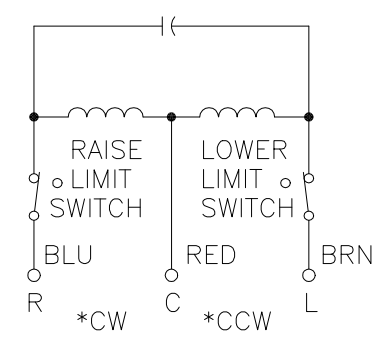

MOTOR CIRCUIT
 120V, 50/60 HZ
 * ROTATION AS VIEWED FROM MOTOR END
 MOTOR SPEED: SEE CHART

NOTES:

- JUMPER PROVIDED IN THE STANDARD COMMON POSITION AND SHOULD BE MOVED OR REMOVED AS REQUIRED.
- IF GANGED UNITS ARE USED IN A SYSTEM THAT ORDINARILY HAS A COMMON NEUTRAL OR GROUND BETWEEN SOURCE AND LOAD, THE NEUTRAL OR GROUND MUST BE CONNECTED TO THE COMMON TERMINALS OF THE VARIABLE TRANSFORMER ASSEMBLY. IF THE SYSTEM HAS NO NEUTRAL, THE LOAD MUST BE BALANCED OR THE TRANSFORMERS WILL BE DAMAGED.

SPECIFICATIONS											
WIRING	INPUT		OUTPUT				SHAFT ROTATION TO INCREASE VOLTAGE	TERMINAL CONNECTIONS			
	VOLTS	HERTZ	VOLTS	CONSTANT CURRENT LOAD MAX. AMPS	CONSTANT IMPEDANCE LOAD MAX. KVA	MAX. AMPS		MAX. KVA	FOR INCREASING VOLTAGE AS VIEWED FROM BASE END		
SINGLE PHASE SERIES	240	50/60	0-240	15	3.60	20	4.80	CW	2-2	4-4	3-3
			0-280	15	4.20	—	—	CCW	4-4	2-2	3-3
									CCW	1-1	4-4
THREE PHASE OPEN DELTA	120	50/60	0-120	15	3.12	20	4.15	CW	2-4-2	4-4	3-4-3
			0-140	15	3.64	—	—	CCW	4-2-4	2-2	3-2-3
									CW	1-4-1	4-4
							CCW	5-2-5	2-2	3-2-3	

SPEED (SECONDS)	MODEL NUMBER	DIM 'A'
5	5M1510-2	15.55 [394.9]
15	15M1510-2	15.55 [394.9]
30	30M1510-2	15.94 [404.9]
60	60M1510-2	15.94 [404.9]

UNLESS OTHERWISE SPECIFIED, TOLERANCE IS # DECIMALS HOLES ANGLES DRAFT UNITS IN [mm]

MATERIAL: ALL DIMENSIONS APPLY AFTER PLATING

TITLE: SPEC. CONTROL DRAWING MOTORIZED VARIABLE XFMR. TYPE: M1510-2

DRAWN BY: TIM RAU DATE: 7/24/98 FIRST USED ON: DO NOT SCALE DWG. CUSTOMER APPROVAL: DATE:

CHECKER: DATE: WEIGHT APPROX. CODE IDENT. NO. 83008 DWG. NO. 031-3733

ENGINEER: DATE: SCALE: .5=1 SHEET 1 OF 1

STACO ENERGY PRODUCTS CO. A COMPONENTS CORPORATION OF AMERICA COMPANY DAYTON, OHIO U.S.A.