

MOTOR CIRCUIT
 120V, 50/60 HZ
 * ROTATION AS VIEWED FROM MOTOR END
 MOTOR SPEED: SEE CHART

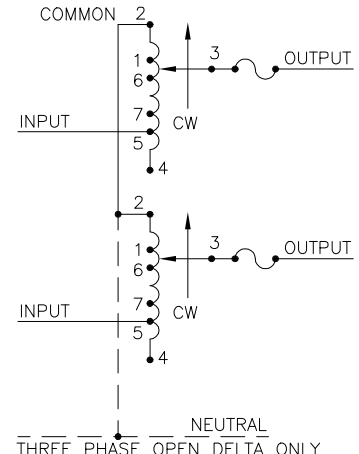

SCHEMATIC
 THREE PHASE OPEN DELTA AND SINGLE PHASE SERIES. FUSE RECOMMENDED BUT NOT SUPPLIED

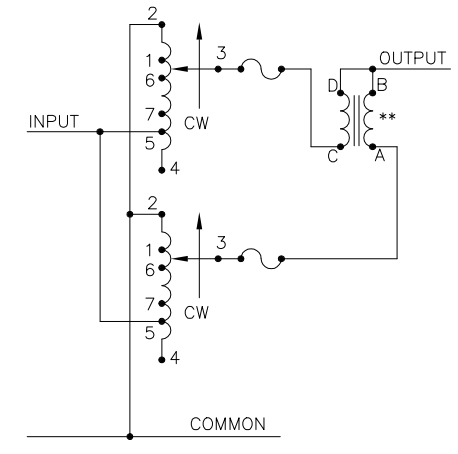

SCHEMATIC
 SINGLE PHASE PARALLEL
 FUSE RECOMMENDED BUT NOT SUPPLIED

SPEED (SECONDS)	MODEL NUMBER
5	5M2520CT-2
15	15M2520CT-2
30	30M2520CT-2
60	60M2520CT-2

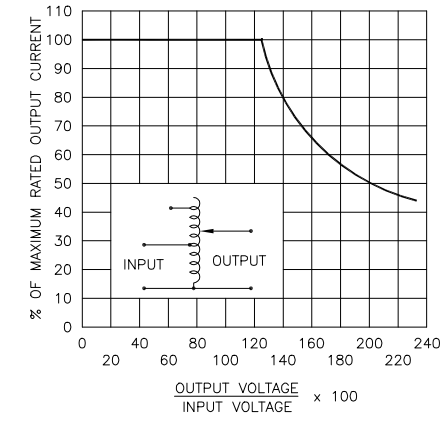

- # MAXIMUM OUTPUT CURRENT IN OUTPUT VOLTAGE RANGE FROM 0 TO 25% ABOVE LINE VOLTAGE. AT HIGHER OUTPUT VOLTAGES, THE OUTPUT CURRENT MUST BE REDUCED ACCORDING TO THE DERATING CURVE FIGURE A.
- § MAXIMUM KVA AT MAXIMUM OUTPUT VOLTAGE AND CORRESPONDING DERATED OUTPUT CURRENT. MAXIMUM KVA FOR LOWER VOLTAGES MAY BE CALCULATED FROM DERATING CURVE FIGURE A.
- ++ LINE TO LINE VOLTAGE.
- ** REQUIRES ONE 52LAC PARALLELING CHOKE (NOT SUPPLIED).
- ∇ IF GANGED UNITS ARE USED IN A SYSTEM THAT ORDINARILY HAS A COMMON NEUTRAL OR GROUND BETWEEN SOURCE AND LOAD, THE NEUTRAL OR GROUND MUST BE CONNECTED TO THE COMMON TERMINALS OF THE VARIABLE TRANSFORMER ASSEMBLY. IF THE SYSTEM HAS NO NEUTRAL, THE LOAD MUST BE BALANCED OR THE TRANSFORMER WILL BE DAMAGED.
- JUMPER PROVIDED IN STANDARD COMMON POSITION AND SHOULD BE MOVED OR REMOVED AS REQUIRED.
- + MOTOR DRIVEN UNITS USE TERMINAL CONNECTIONS FOR CCW INCREASING VOLTAGE, AS VIEWED FROM THE BASE END.

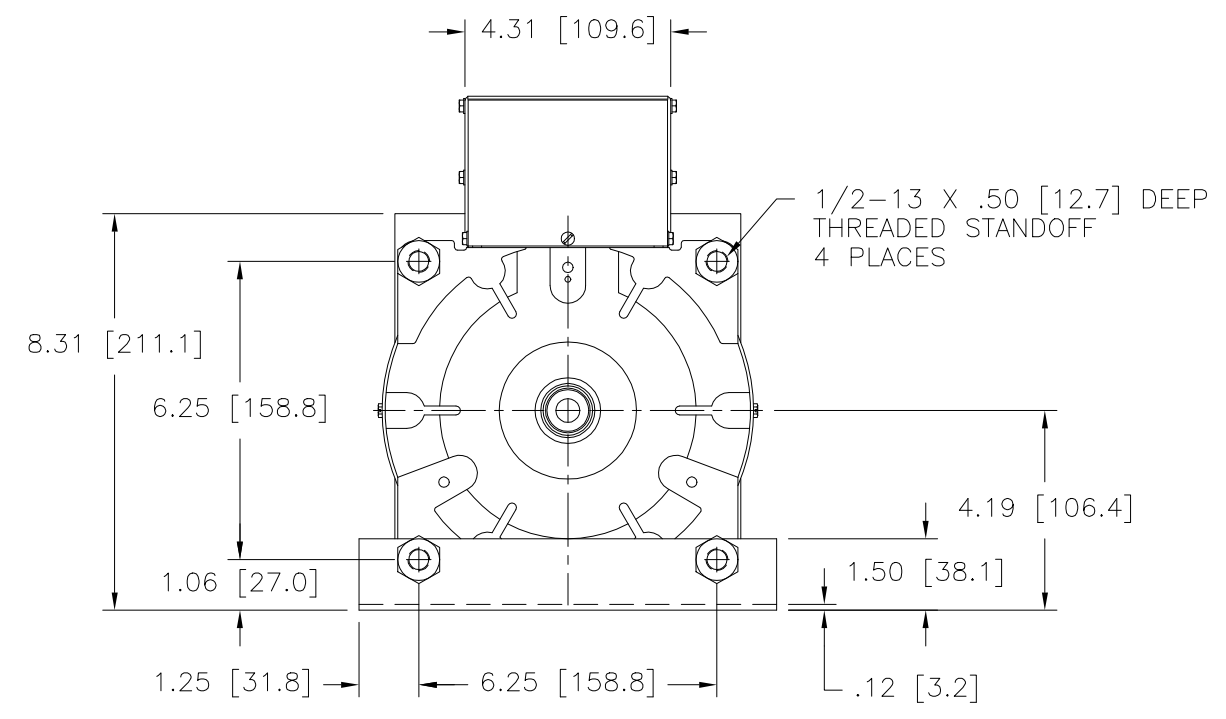

WIRING	INPUT		OUTPUT				SHAFT ROTATION TO INCREASE VOLTAGE	TERMINAL CONNECTIONS + MOTOR DRIVEN UNITS USE CCW FOR INCREASING VOLTAGE AS VIEWED FROM BASE END ■			
	VOLTS	HERTZ	VOLTS	CONSTANT CURRENT LOAD		CONSTANT IMPEDANCE LOAD		INPUT	JUMPER	OUTPUT	
				MAX. AMPS	MAX. KVA	MAX. AMPS					MAX. KVA
SINGLE PHASE PARALLEL **	240	50/60	0-240	20	4.80	26	6.20	CW	2-2,4-4	4-B	
			0-280	20	5.60	—	—	CCW	2-2,4-4	2-B	
	120	50/60	0-280	20#	2.40 §	—	—	CW	1-1,4-4	4-B	
			0-280	20#	2.40 §	—	—	CCW	5-5,2-2	2-B	
SINGLE PHASE SERIES	480	50/60	0-480	10	4.80	13	6.24	CW	2-2	4-4 3-3	
			0-560	10	5.60	—	—	CCW	4-4	2-2 3-3	
	240	50/60	0-560	10#	2.40 §	—	—	CW	1-1	4-4 3-3	
			0-560	10#	2.40 §	—	—	CCW	5-5	2-2 3-3	
THREE PHASE OPEN DELTA ∇	240	50/60	0-240	10	4.20	13	5.40	CW	2-4-2	4-4 3-4-3	
			0-280	10	4.85	—	—	CCW	4-2-4	2-2 3-2-3	
	120	50/60	0-280	10#	2.10 §	—	—	CW	1-4-1	4-4 3-4-3	
			0-280	10#	2.10 §	—	—	CCW	5-2-5	2-2 3-2-3	

UNLESS OTHERWISE SPECIFIED, TOLERANCE IS ±
 DECIMALS HOLES ANGLES DRAFT
 .XX .0000 .06 .0000 .01 1° 1-1/2°

UNITS IN [mm]

MATERIAL: ALL DIMENSIONS APPLY AFTER PLATING

TITLE: SPEC. CONTROL DRAWING
 VARIABLE TRANSFORMER
 MODEL: M2520CT-2

STACO ENERGY PRODUCTS CO.
 A COMPONENTS CORPORATION OF AMERICA COMPANY
 DAYTON, OHIO U.S.A.

DRAWN BY S.A. SMITH DATE 1/4/2001 FIRST USED ON DO NOT SCALE DWG. CUSTOMER APPROVAL DATE

CHECKER DATE WEIGHT APPROX. 60 LBS CODE IDENT. NO. 83008 DWG. NO. 031-5793

ENGINEER DATE SCALE 1/2 SHEET 1 OF 1