

Variable Transformers
Series 1000 • 3.5 to 10.0 Amperes



1000 Series

STACO's 1010B operates on 120 volts and is rated for constant current of 10 amperes. The 1020B operates on 240 volts and constant current of 3.5 amperes. Coil tapping arrangements allow for 0 to input line voltage or 17% above line voltage. These variable transformers may be operated from 50-1500 hertz with no reduction in output current.

Uncased models have the shaft extending from the base end. This shaft is fully adjustable and can be extended from either end for general utility mounting. Cased styles, which have a "CT" suffix, feature the protective screening over the coil

assembly and a terminal box cover with knock-outs to accept conduit.

Motor driven units are available in single, two and three ganged assemblies; cased or uncased styles as identified by the prefix "M" in the type number. If a motor driven model is ordered, be sure to prefix the part number with the desired travel time from 0 to maximum of 5, 15, 30, or 60 seconds.

The synchronous motor is designed for operation on 120 volts, 50/60 hertz single phase lines and draws approximately 0.3 amperes.

PART NO.	WIRING	INPUT		OUTPUT				SHAFT ROTATION FOR VOLTAGE INCREASE	TERMINAL CONNECTIONS (For increasing Voltage) As Viewed from Base End			SCHE-MATIC (Pg 8 & 9)	NET WT. LBS.	(Max) MOTOR DRIVEN			
		VOLTS	HERTZ	VOLTS	CONSTANT CURRENT LOAD		CONSTANT IMPEDANCE LOAD		Input	Jumper*	Output						
					MAX AMPS	MAX KVA	MAX AMPS								MAX KVA		
1010B 1010BCT M1010B† M1010BCT†	Single Phase	120	50/60	0-120	10	1.2	13	1.56	CW	1-4	—	4-3	10	10 1/4	16 3/4		
										CCW	1-4	—				1-3	
				0-140	10	1.4	—	—		CW	4-5	—				4-3	
										CCW	1-2	—				1-3	
1010B-2 1010BCT-2 M1010B-2† M1010BCT-2†	Single Phase Series	240	50/60	0-240	10	2.4	13	3.12	CW	1-1	4-4	3-3	10 & 4	22 1/2	30 7/8		
										CCW	4-4	1-1				3-3	
				0-280	10	2.8	—	—		CW	5-5	4-4				3-3	
										CCW	2-2	1-1				3-3	
	Three Phase Open Delta π	120++	50/60	0-120	10	2.08	13	2.70	CW	1-4-1	4-4	3-4-3	10 & 5				
										CCW	4-1-4	1-1				3-1-3	
				0-140	10	2.42	—	—		CW	5-4-5	4-4				3-4-3	
										CCW	2-1-2	1-1				3-1-3	
1010B-3 1010BCT-3 M1010B-3† M1010BCT-3†	Three Phase Wye π	240++	50/60	0-240	10	4.16	13	5.4	CW	1-1-1	4-4-4	3-3-3	10 & 6	34 1/2	42 1/2		
									CCW	4-4-4	1-1-1	3-3-3					
		60	0-280	10	4.85	—	—		CW	5-5-5	4-4-4	3-3-3					
								CCW	2-2-2	1-1-1	3-3-3						
3PN1010B	Single Phase	120	50/60	0-140	10‡	1.4	—	—	CW	LINE CORD & RECEPTACLE			3	10 1/4	—		
3PN1010BA 3PN1010BV	Single Phase	120	50/60	0-140	10‡	1.4	w/Ammeter w/Voltmeter		CW	LINE CORD & RECEPTACLE			9	10 1/4	—		
1020B 1020BCT M1020B† M1020BCT†	Single Phase	240	50/60	0-240	3.5	0.84	5.0	1.20	CW	1-4	—	4-3	12	10 1/4	16 3/4		
										CCW	1-4	—				1-3	
				0-280	3.5	0.98	—	—		CW	4-5	—				4-3	
										CCW	1-2	—				1-3	
		120	50/60	0-280	3.5#	0.42§	—	—		CW	4-7	—	4-3				
										CCW	1-6	—	1-3				
1020B-2 1020BCT-2 M1020B-2+ M1020BCT-2+	Single Phase Series	480	50/60	0-480	3.5	1.68	5.0	2.4	CW	1-1	4-4	3-2	12 & 4	22 1/2	30 3/4		
										CCW	4-4	1-1				3-3	
		0-560	3.5	1.96	—	—		CW	5-5	4-4	3-3						
								CCW	2-2	1-1	3-3						
		240	50/60	0-560	3.5#	0.84§	—	—	CW	7-7	4-4	3-3					
								CCW	6-6	1-1	3-3						
	Three Phase Open Delta π	240++	50/60	0-240	3.5	1.45	5.0	2.08	CW	1-4-1	4-4	3-4-3	12 & 5				
										CCW	4-1-4	1-1				3-1-3	
		0-280	3.5	1.70	—	—		CW	5-4-5	4-4	3-4-3						
								CCW	2-1-2	1-1	3-1-3						
		120++	50/60	0-280	3.5#	0.73§	—	—	CW	7-4-7	4-4	3-4-3					
								CCW	6-1-6	1-1	3-1-3						
1020B-3 1020BCT-3 M1020B-3 M1020BCT-3	Three Phase Wye π	480++	50/60	0-480	3.5	2.91	5.0	4.16	CW	1-1-1	4-4-4	3-3-3	12 & 6	34 1/2	42 1/4		
									CCW	4-4-4	1-1-1	3-3-3i					
		60	0-560	3.5	3.40	—	—		CW	5-5-5	4-4-4	3-3-3					
								CCW	2-2-2	1-1-1	3-3-3						
		240++	60	0-560	3.5#	1.46§	—	—	CW	7-7-7	4-4-4	3-3-3					
								CCW	6-6-6	1-1-1	3-3-3						
3PN1020B	Single Phase	240	50/60	0-280	3.5‡	0.98	—	—	CW	LINE CORD & RECEPTACLE			3	10 1/4	—		
3PN1020BA 3PN1020BV	Single Phase	240	50/60	0-280	3.5‡	0.98	w/Ammeter w/Voltmeter		CW	LINE CORD & RECEPTACLE			9	10 1/4	—		

* Jumper provided in the standard common position and should be moved or removed as required.
 ++ Line to line voltage
 ‡ Unit is fused for the constant current rating at the factory.
 † Motor driven units use terminal connections for CCW increasing voltage, as viewed from the base end. See Fig 23 on page 9 for motor wiring.
 § Maximum KVA at maximum output voltage and corresponding derated output current. Maximum KVA for lower voltages may be calculated from derating curve Figure B, page 6.

π If ganged units are used in a system that ordinarily has a common neutral or ground between source and load, the neutral or ground must be connected to the common terminals of the variable transformer assembly. If the system has no neutral, the load must be balanced or the transformers will be damaged.
 # Maximum output current in output voltage range from 0 to 25% above line voltage. At higher output voltages, the output current must be reduced according to the derating curve, Figure B, page 6.

1000/1200 Series

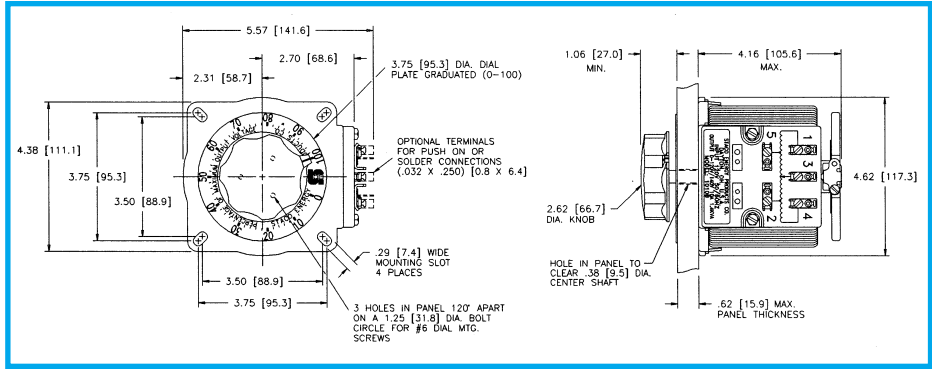
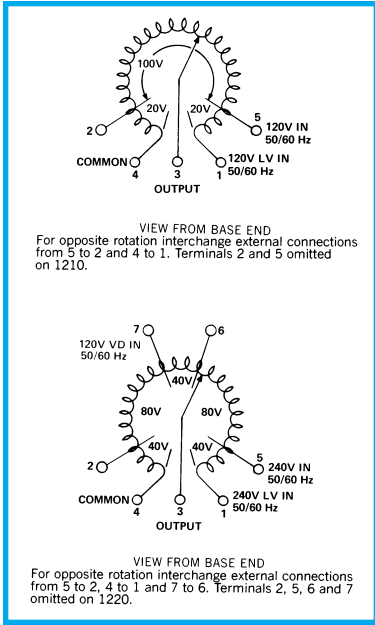

Single Unit, Uncased

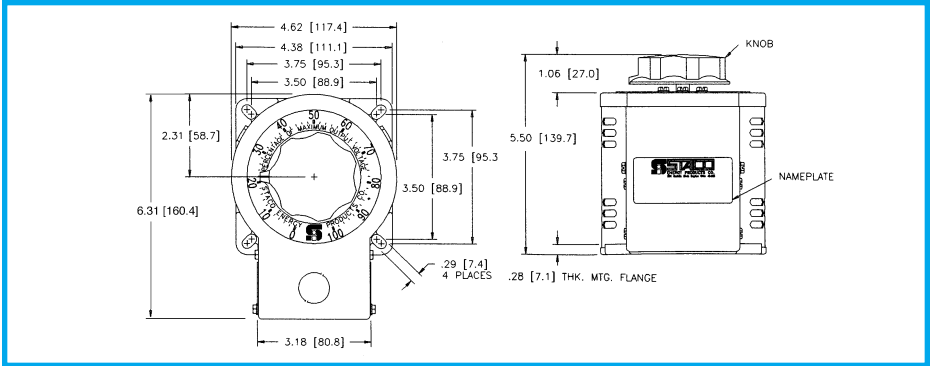

Single Unit, Cased



1010B

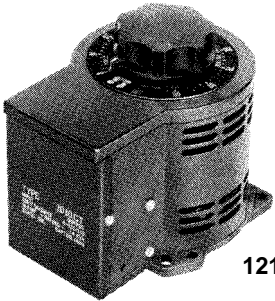

1210BCT

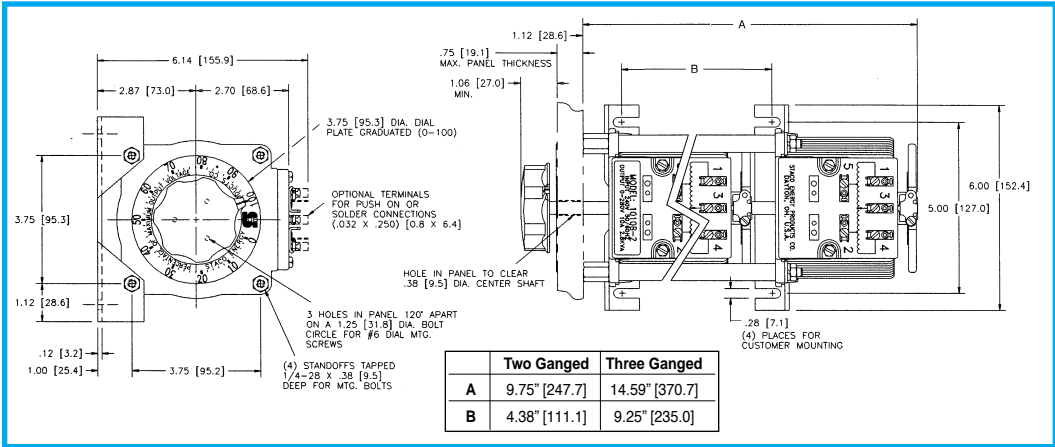

Two and Three Ganged, Uncased

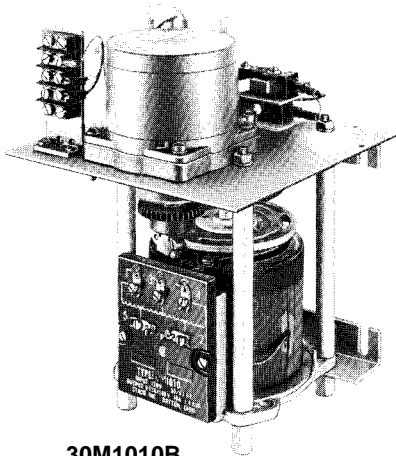

30M1010B

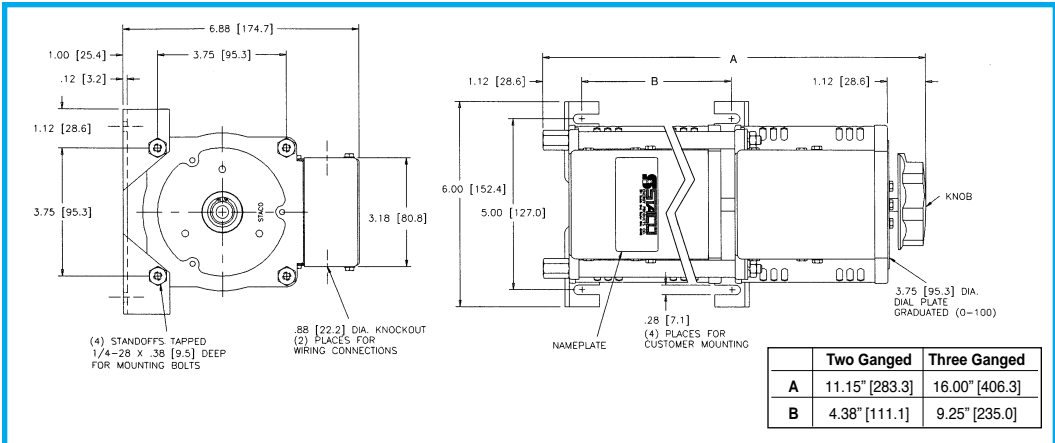

Two and Three Ganged, Cased

1000/1200 Series

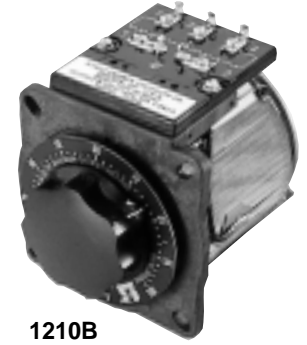
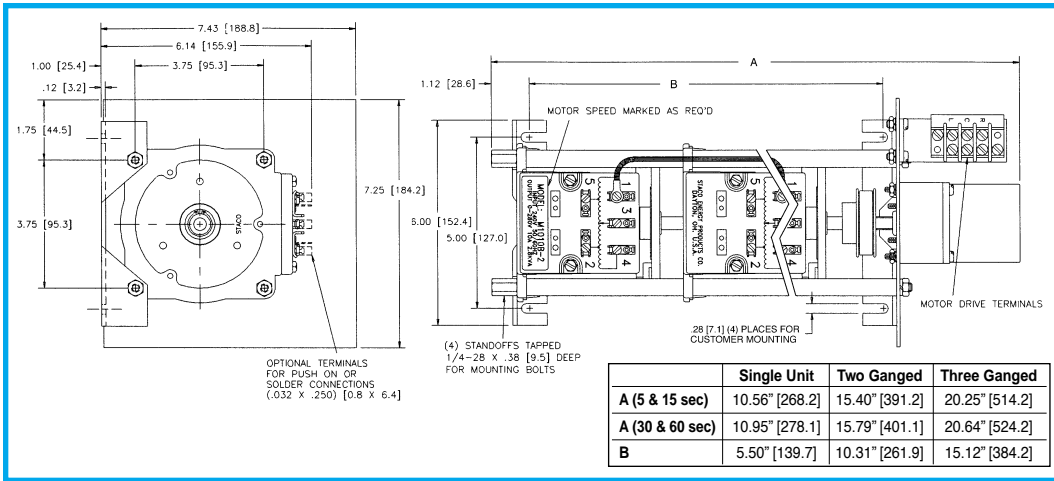

1210B
Front View

Motorized Single, Two and Three Ganged, Uncased

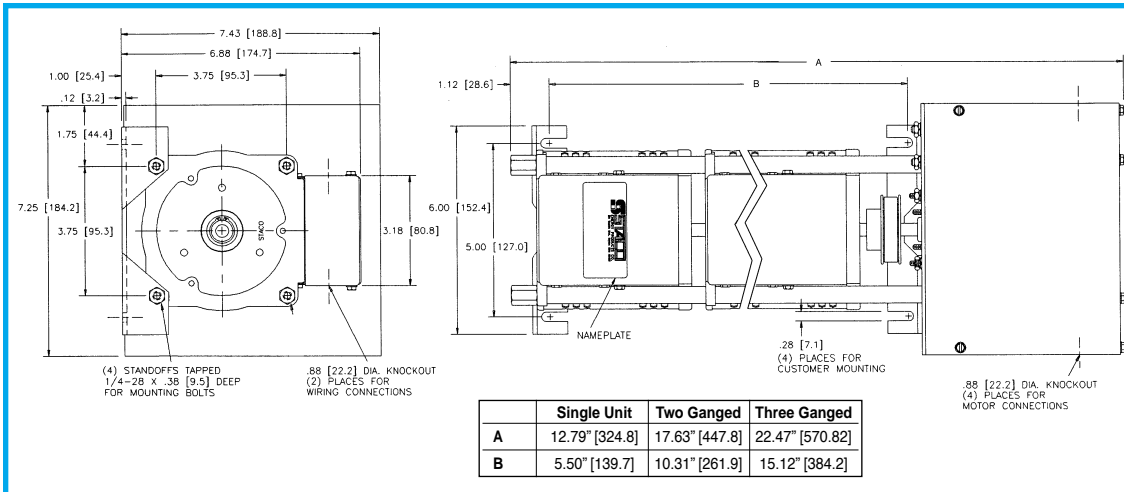

1210B
Rear View

Motorized Single, Two and Three Ganged, Cased

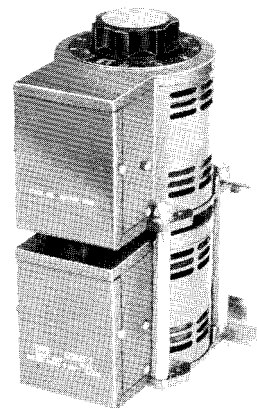

1220BCT-2

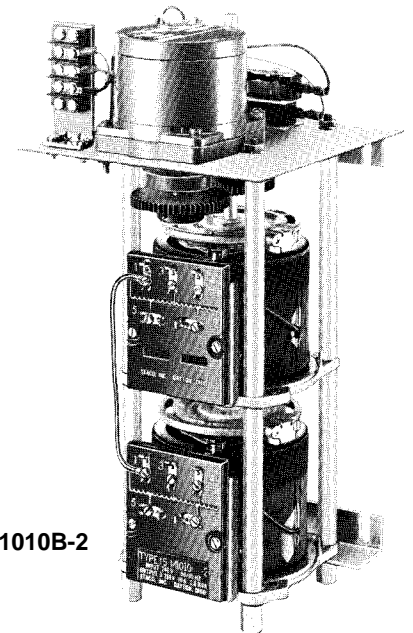

15M1010B-2